

RADIANT CONE FLAME BURNERS

RAD-65, RAD-120 SERIES

FEATURES

- Body mixer: cast iron G25
- Mounting plate WMF: iron
- Gas pipe: AISI310
- Pre-heated air: up to 450 °C
- Adequate to different types of gas: CH₄/L.P./propane/etc.
- Standard refractory block, max. temp.: 1750 °C
- Capacity range: 650 to 1200 kW
- Excellent flame stability with:
 - excess air
 - excess fuel
 - on ratio firing
- Low NO_x level.
- Wall mounting flanges to fasten the block holder to the furnace shell are threaded to allow for positioning of accessories: pilot burner, flame detectors (electrodes or UV scanners), peepsight.
- Separated air and gas inlets, mixing at discharge point, no flashback.

APPLICATIONS

- Annealing furnaces.
- Forging furnaces.
- Frit melting furnace.
- Billets re-heating furnace.
- Reverberatory furnaces.
- Aluminium melting furnace.

DESCRIPTION

Radiant cone flame burners, model RAD-65 and RAD-120, are nozzle mix burners.

Gas and air are mixed only at the point of discharge. High-velocity air flow produces a negative vortex at the refractory block mouth. Gas enters the vortex, mixing rapidly, producing intense combustion. The shape of the block and the vortex create a conic-shaped concentration. Cone temperatures are controlled by the percentage of excess air used.



F3001101

INSTALLATION

RAD-65 and RAD-120 burners may be mounted to operate in any position. For wall mounting use mounting plate WMF. The furnace refractory should be set to leave some room on all sides of the block. This space should be packed with refractory material, for example ceramic fiber and protected by 20 mm of refractory concrete on the wall to allow for expansion of the different material used walls (see technical note). Lifting eye bolt hangers are available and may be mounted on the anchor extensions for furnace roof suspension installations. Flexible connectors are recommended for air and gas connections at the burner to allow for slight movement or misalignment of piping and are absolutely essential when pre-heated air is involved. Air and gas connections are Pyronics standard, welding or threaded flanged type. They may rotate by 90°.



Headquarters
Esa S.r.l.
Via E. Fermi 40 I-24035 Curno (BG) - Italy
Tel. +39.035.6227411 - Fax +39.035.6227499
esa@esacombustion.it - www.esapyronics.com

International Sales
Pyronics International S.A./N.V.
Zoning Ind., 4ème rue B-6040 Jumet - Belgium
Tel +32.71.256970 - Fax +32.71.256979
marketing@pyronics.be

IGNITION AND FLAME DETECTION

RAD-65 and RAD-120 burners must be ignited at low fire via pilot burner P86PBST. Pilot burners must not remain ignited, therefore flame detection must be done through UV- scanner located

anticlockwise. Flame detection systems are required on all burners with furnace temperatures below 750°C.

Catalog No.	Pilot burner ignition		Electrode ignition	
	Ignition	Detection	Ignition	Detection
RAD-65	P86PBST	UV-2 / 6EN-300 *	(non available)	(non available)
RAD-120	P86PBST	UV-2 / 6EN-300 *	(non available)	(non available)

(*) In most cases, we suggest you to make flame detection through UV- scanner. In some particular cases, it is possible to use continue pilot burner with detection electrode.

CAPACITY TABLE

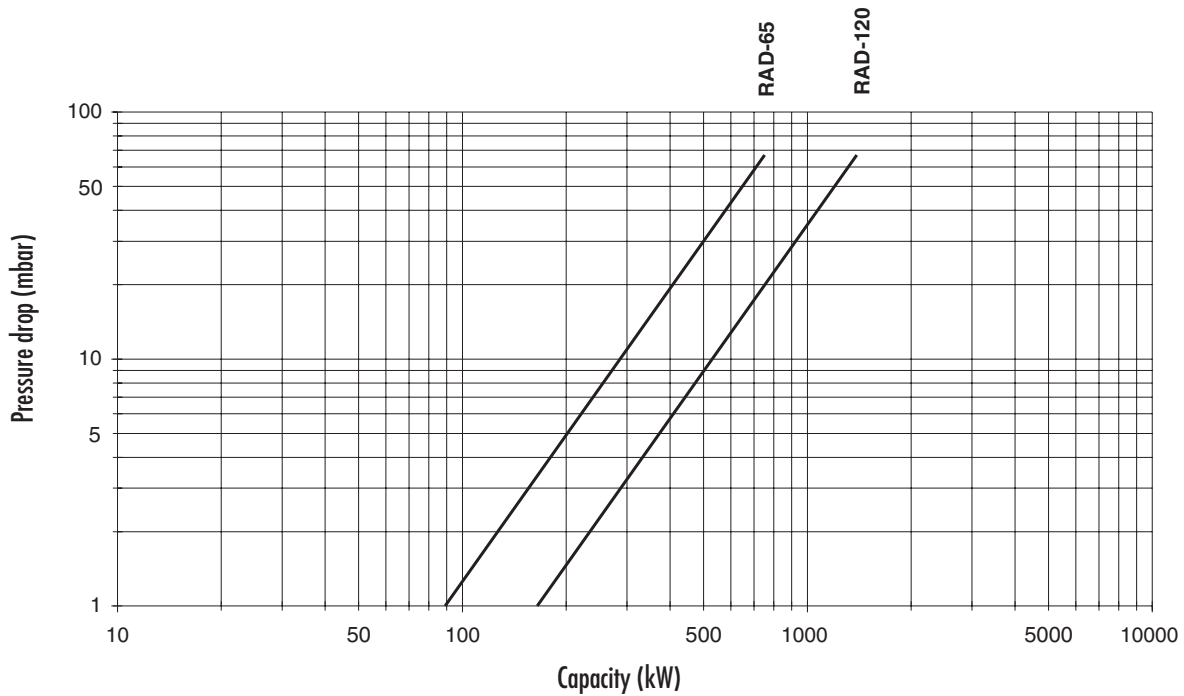

63001101

NOTE

Gas pressures required 10 mbar above maximum air pressure used for direct loaded systems.
 Minimum gas pressure 10 mbar for bleed loader and excess air systems.

FLAME DIMENSION TABLE

Catalog No.	Flame lenght mm	Flame width mm
RAD-65	750 ÷ 1000	750
RAD-120	1000 ÷ 1500	1000

NOTE:

Flame lenght are approximate, referred to burner feeded with natural gas, free air, working at stoichiometric ratio and at nominal capacity.

FLOW CHART (ON RATIO FIRING)

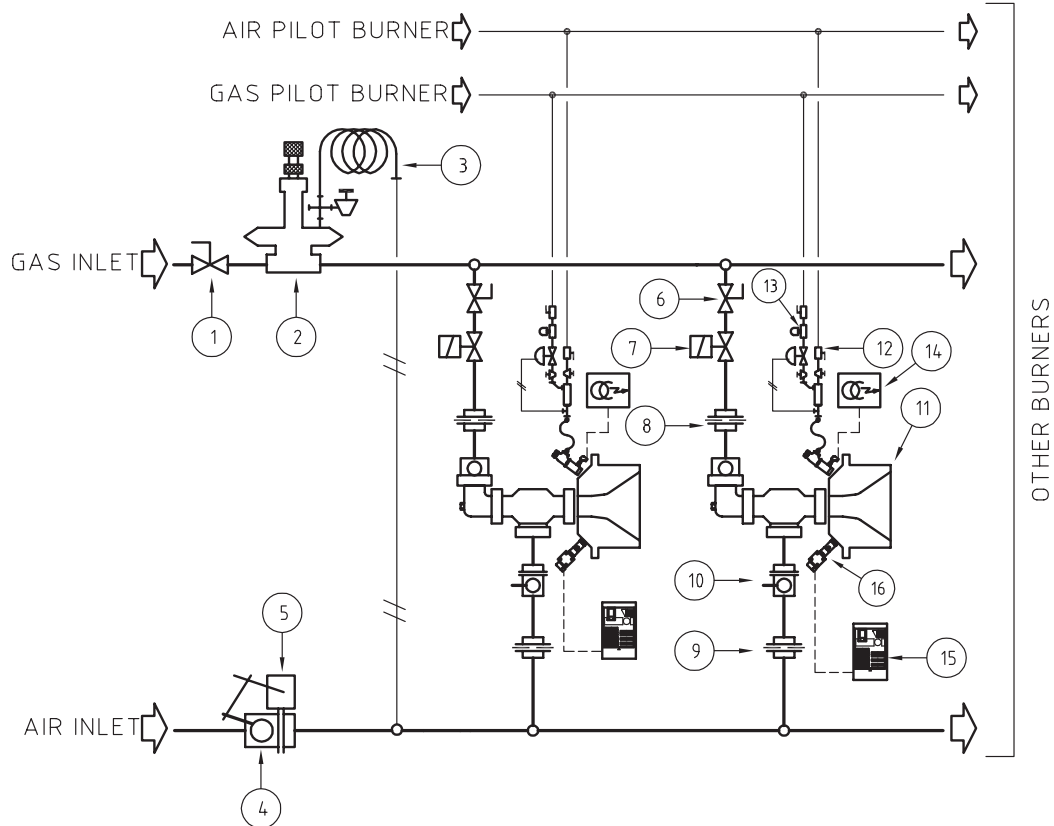

Pos.	Model Identification
1	Main gas ball valve
2	Zero regulator
3	Impulse line
4	Motorized air valve
5	Electric control
6	Gas ball valve to each burner
7	Main burner safety solenoid gas valve
8	Orifice flow meter for ΔP gas
9	Orifice flow meter for ΔP air
10	Manual butterfly air valve
11	Radiant cone flame burner
12	Pilot burner
13	Pilot burner safety solenoid gas valve
14	Ignition transformer
15	Flame detection
16	UV scanner

D3001101

FLOW CHART (EXCESS AIR)

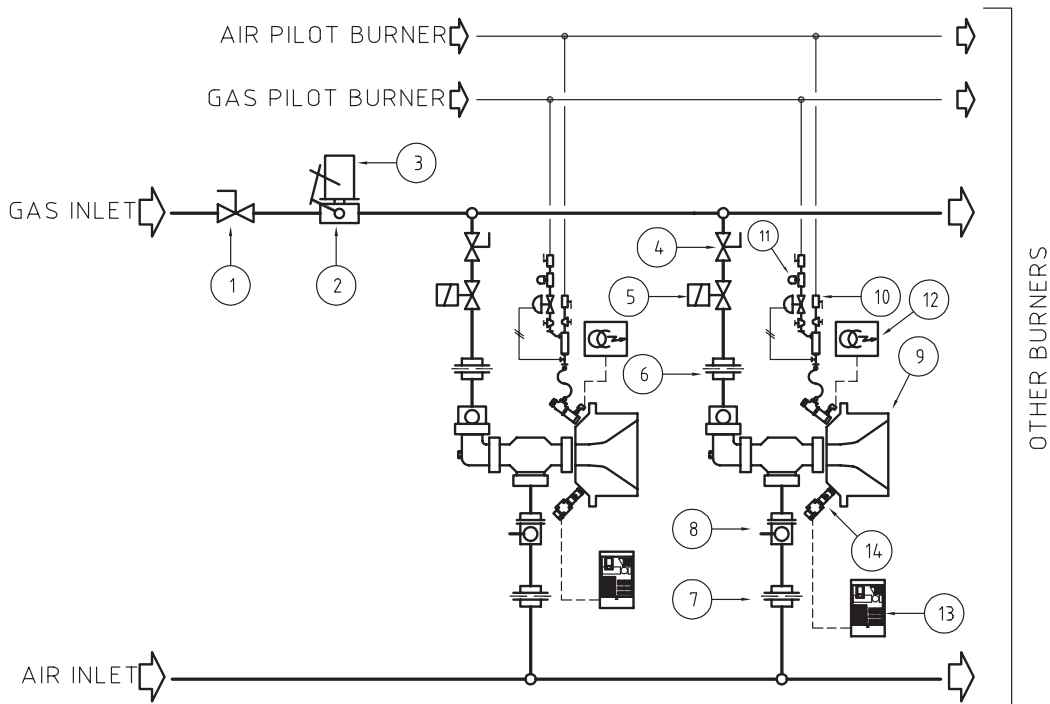

Pos.	Model Identification
1	Main gas ball valve
2	Motorized gas valve
3	Electric control
4	Gas ball valve to each burner
5	Main burner safety solenoid gas valve
6	Orifice flow meter for ΔP gas
7	Orifice flow meter for ΔP air
8	Manual air butterfly valve
9	Radiant cone flame burner
10	Pilot burner
11	Pilot burner safety solenoid gas valve
12	Ignition transformer
13	Flame detection
14	UV scanner

D3001102

DIMENSIONS

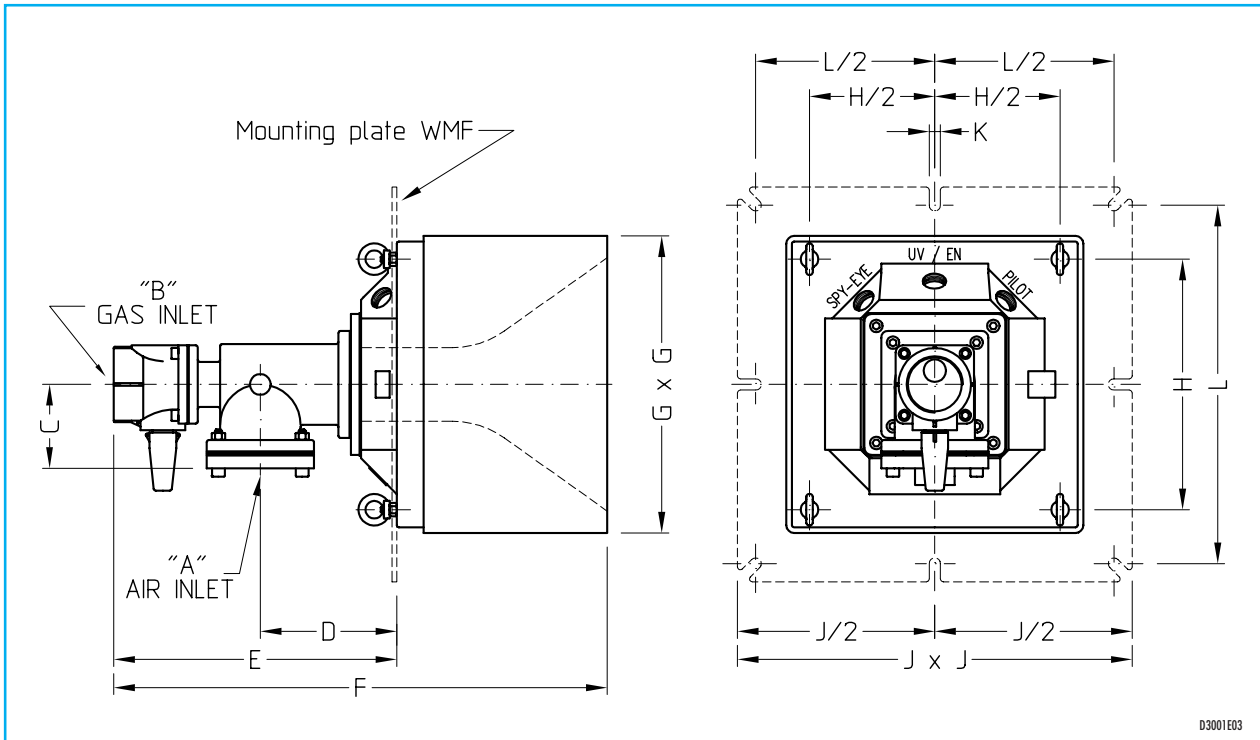

Catalog no.	ø Pilot	ø UV-EN	ø Peepsight	ø A	ø B	C mm	D mm	E mm	F mm	G mm	J mm	H mm	K mm	L mm
RAD-65-GA	G - 1"	G - 1"	G - 1"	DN 100	G - 2.1/2"	105	194	308	657	419	508	356	16	464
RAD-120-GA	G - 1"	G - 1"	G - 1"	DN 150	G - 3"	135	205	394	743	533	610	406	16	564

Catalog no.	ø Pilot	ø UV-EN	ø Peepsight	ø A	ø B	C mm	D mm	E mm	F mm	G mm	J mm	H mm	K mm	L mm
RAD-65-GA-TEK	G - 1.1/2"	G - 1"	G - 1"	DN 100	G - 2.1/2"	105	194	308	657	419	508	356	16	464
RAD-120-GA-TEK	G - 1.1/2"	G - 1"	G - 1"	DN 150	G - 3"	135	205	394	743	533	610	406	16	564

DIMENSIONS

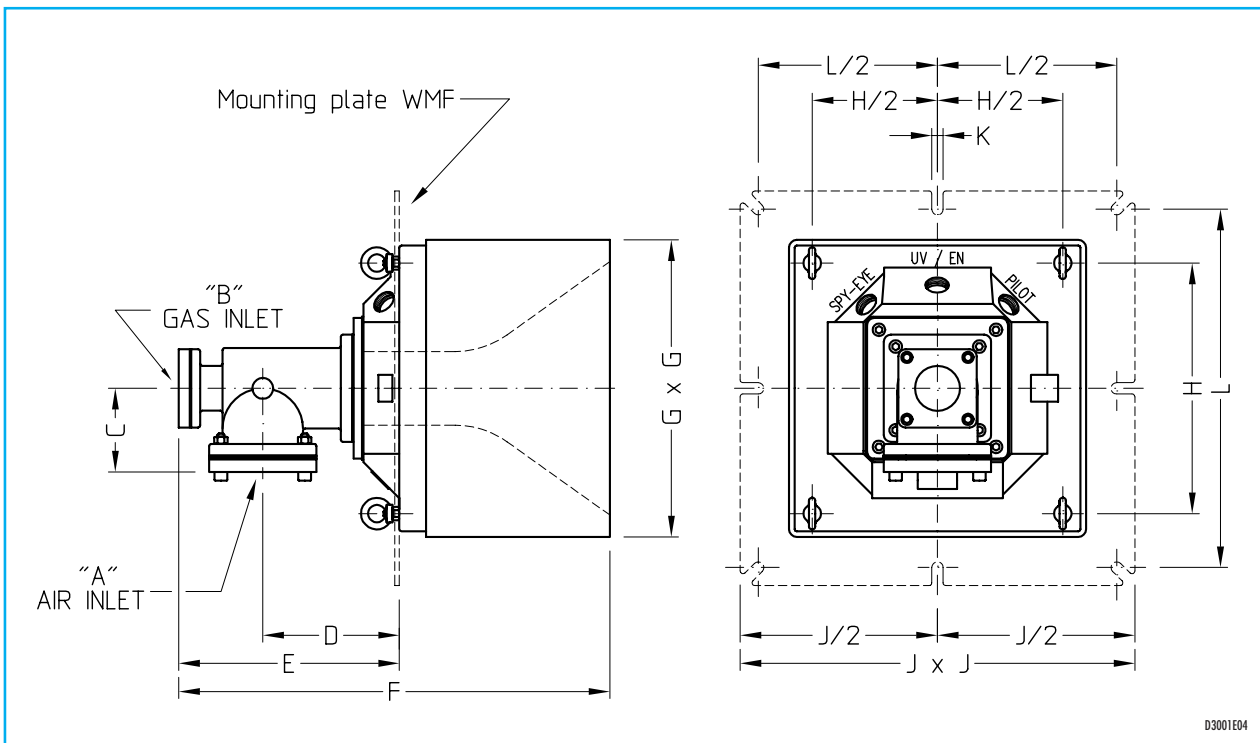

Catalog no.	ø Pilot	ø UV-EN	ø Peepsight	ø A	ø B	C mm	D mm	E mm	F mm	G mm	J mm	H mm	K mm	L mm
RAD-65-F	G - 1"	G - 1"	G - 1"	DN 100	DN 65	105	194	280	629	419	508	356	16	464
RAD-120-F	G - 1"	G - 1"	G - 1"	DN 150	DN 80	135	205	330	679	533	610	406	16	564

Catalog no.	ø Pilot	ø UV-EN	ø Peepsight	ø A	ø B	C mm	D mm	E mm	F mm	G mm	J mm	H mm	K mm	L mm
RAD-65-F-TEK	G - 1.1/2"	G - 1"	G - 1"	DN 100	DN 65	105	194	280	629	419	508	356	16	464
RAD-120-F-TEK	G - 1.1/2"	G - 1"	G - 1"	DN 150	DN 80	135	205	330	679	533	610	406	16	564

ORDERING CODES - BURNER

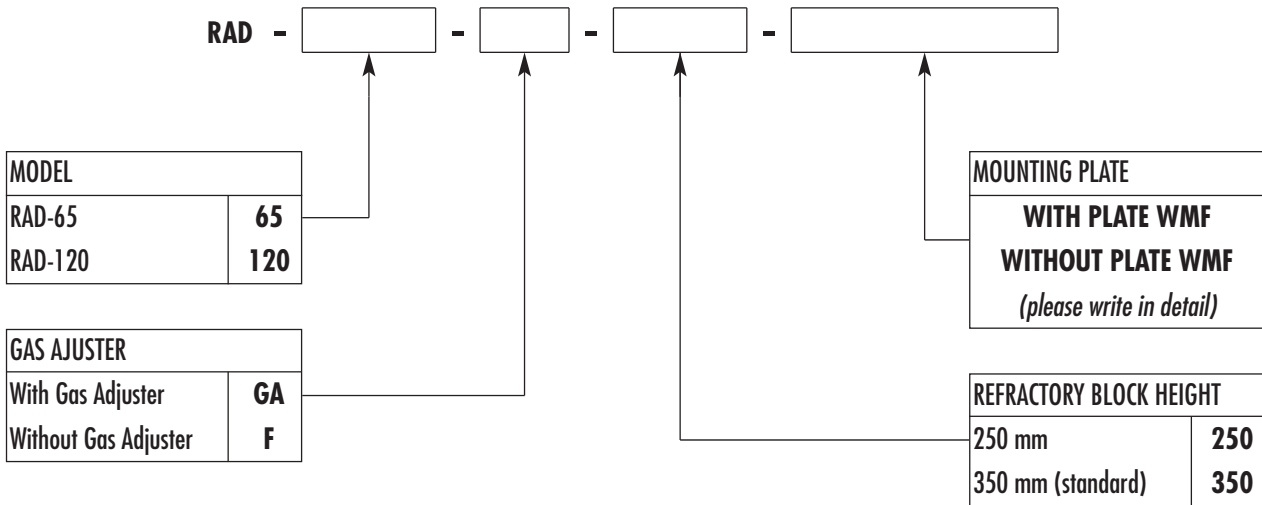

RAD-TEK: special version for 1.1/2" pilot

ORDERING CODES - REFRACTORY BLOCK ONLY

