

# PACKAGED METALLIC BURNERS

## FC SERIES

### FEATURES

- Burner body: iron
- Burner cone: AISI310
- Nozzle: AISI304
- Optional shield: AISI310
- Capacity range: 145 to 435 kW
- Adequate to different types of gas: CH<sub>4</sub>/L.P./propane/etc.
- Excellent flame stability with: excess air on ratio firing
- Low No<sub>x</sub> level.
- Wide turndown range.
- High excess air.
- Easily replaced electrodes.
- Separated air and gas inlets, mixing at discharge point, no flashback.
- Compact, light, small burner supplied with air blower, pressure switch, gas adjuster, flame and sight electrodes, peepsight, orifice flow meter (CH<sub>4</sub>/L.P.).

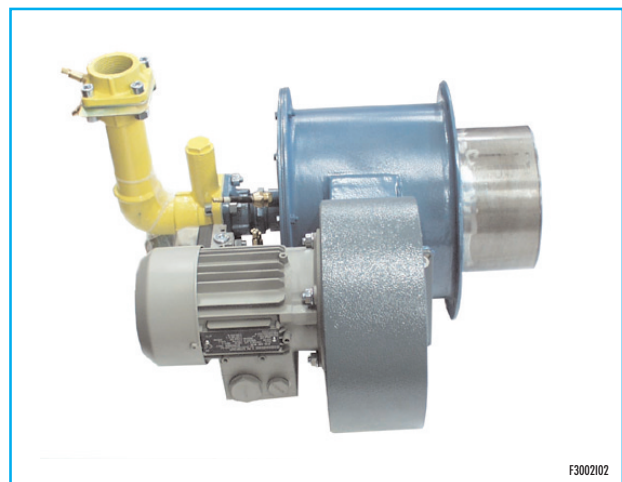

### APPLICATIONS

- Air heaters.
- Steam generators.
- Incinerators.
- Driers.
- Foodstuffs ovens.
- Textile and dyeing machines (Rameuse).



## DESCRIPTION

FC burners are used in low temperature processes. An air blower is mounted on the burner and supplies the air necessary for combustion. The air flow is always the same and thermoregulation occurs in excess air therefore varying the gas flow. This ensures excellent flame stability over varying operating conditions and subsequent homogeneous temperature and air in the combustion chamber. The nozzle allows for extremely high turndown ranges, from 30÷1 to 50÷1 according to the model.

FC burners are simple and easy to install thanks to their compactness, metallic construction, light weight and small size. They are particularly adequate to operate with negative or atmospheric pressure combustion chambers. If they are mounted on positive pressure combustion chambers, it is necessary to know their true capacity to obtain better results.

FC burners are on-off, two steps or modulating systems.

## INSTALLATION

FC burners may be installed to operate in any position. Use mounting flange with standard threading. The gas inlet may be rotated and is equipped with gas adjuster, model GAF. A refractory block or steel

flame shield may be supplied on request. The entirely pre-mounted version with all the devices for the supply gas pipe (see the enclosed charts) is also available.

## IGNITION AND FLAME DETECTION

Burner ignition is achieved by a direct spark ignition electrode Wand; a pilot burner P42PBST-W/X may be also supplied on request. Flames can be monitored using an electrode WAND; UV-2 ultraviolet

scanners may also be used on request.

Flame detection systems are required on all burners with furnace temperature below 750°C.

Catalog No.	Pilot burner ignition		Electrode ignition	
	Ignition	Detection	Ignition	Detection
FC-5	P42PBST-W/X	Wand / UV-2	Wand	Wand / UV-2
FC-10	P42PBST-W/X	Wand / UV-2	Wand	Wand / UV-2
FC-15	P42PBST-W/X	Wand / UV-2	Wand	Wand / UV-2

## FLAME DIMENSIONS - CAPACITY TABLE

Catalog No.	Flame lenght mm	Capacity kW	Flame diameter mm
FC-5	400 ÷ 600	145	190
FC-10	600 ÷ 800	290	240
FC-15	800 ÷ 1200	435	290

### NOTE:

Flame lenght are approximate, referred to burner feeded with natural gas, free air, working at stoichiometric ratio and at nominal capacity.

## NATURAL GAS CAPACITY TABLE

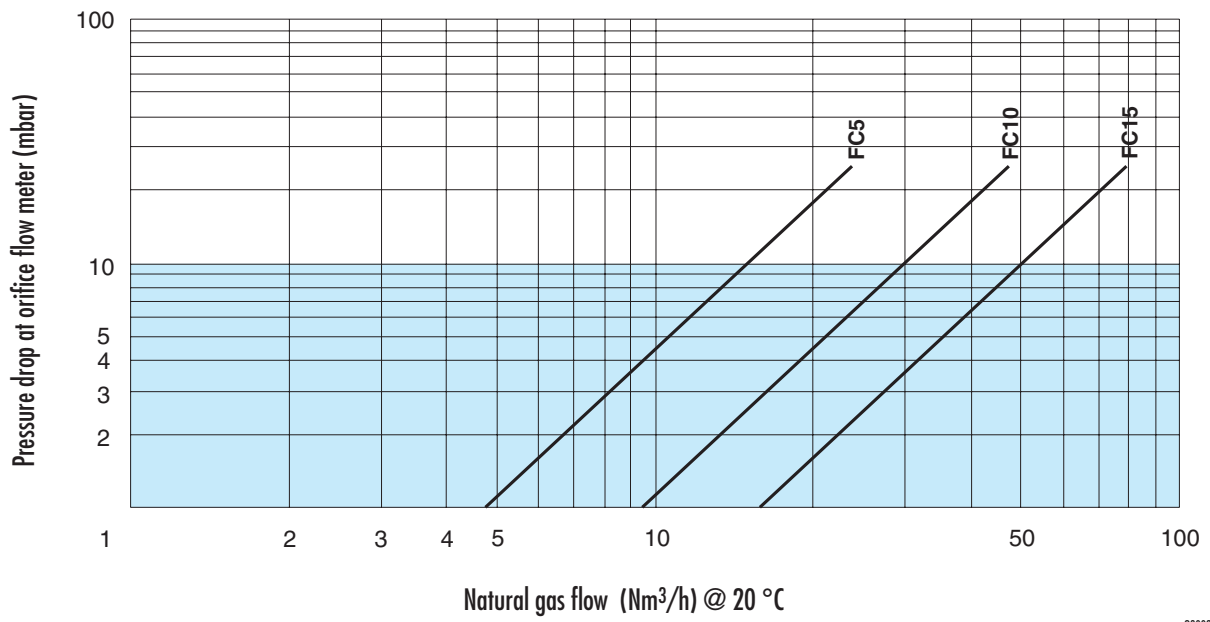

G3002101

## L.P. CAPACITY TABLE

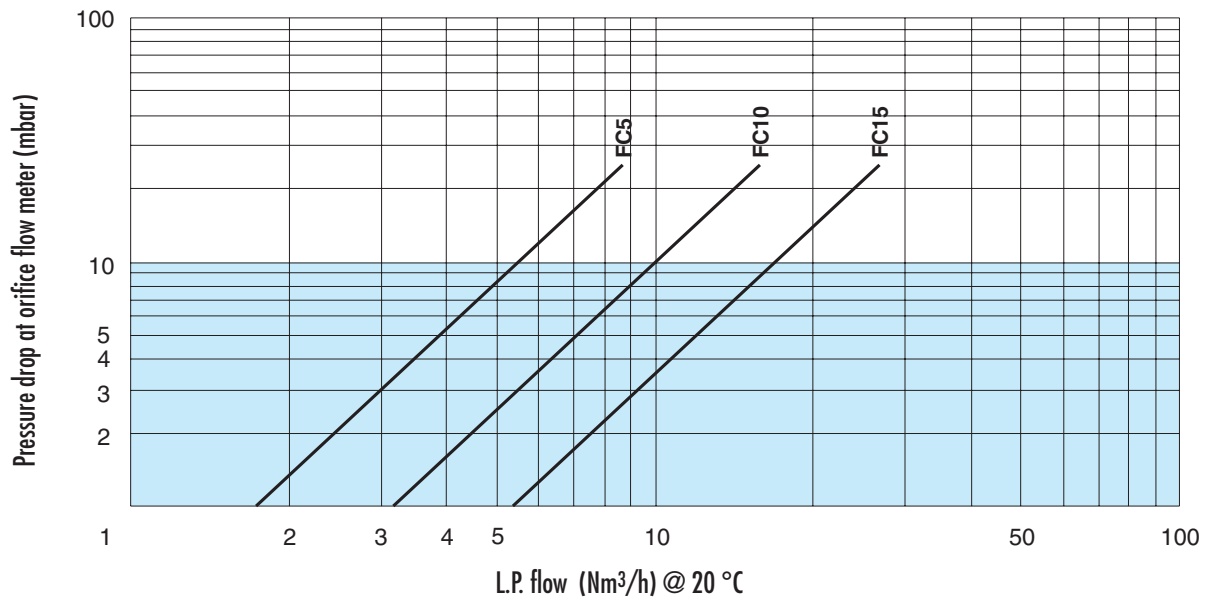

G3002102

## FLOW CHART (ON-OFF)

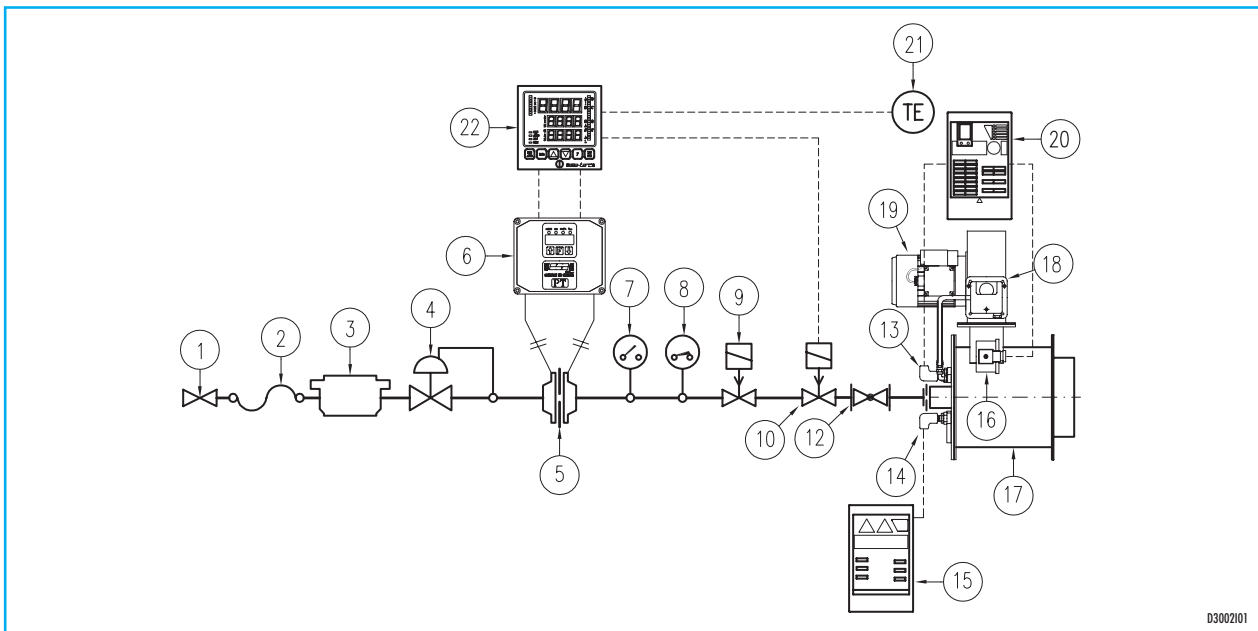

POS.	Model identification	FC-5	FC-10	FC-15
1	Gas ball valve	8RS0/T ø1"	12RS0/T ø1.1/2"	12RS0/T ø1.1/2"
2	Flexible connector	8FN ø1"	12FN ø1.1/2"	12FN ø1.1/2"
3	Gas filter	"G" ø1"	"G" ø1.1/2"	"G" ø1.1/2"
4	Reducing regulator	SR-6 ø3/4"	SR-8 ø1"	SR-12 ø1.1/2"
5	Orifice flow meter	8POP-U-S	12POP-U-S	12POP-U-S
6	Flow indicator	ESA PT	ESA PT	ESA PT
7	Low pressure gas limit switch	DG-50-U	DG-50-U	DG-50-U
8	High pressure gas limit switch	DG-500-U	DG-500-U	DG-500-U
9	Rapid opening safety solenoid valve	VM-R3 ø1"	VM-R4 ø1.1/2"	VM-R4 ø1.1/2"
10	Slow opening safety solenoid valve	VM-L3 ø1"	VM-L4 ø1.1/2"	VM-L4 ø1.1/2"
12	Gas adjuster	8GAF8 ø1"	12GAF12 ø1.1/2"	12GAF12 ø1.1/2"
13	Flame rod	WAND	WAND	WAND
14	Spark electrode	WAND	WAND	WAND
15	Ignition transformer	TRAFO	TRAFO	TRAFO
16	UV-scanner with housing	UV2-CHLG2	UV2-CHLG2	UV2-CHLG2
17	Metallic burner	FC-5	FC-10	FC-15
18	Low pressure air limit switch	DG-6-U	DG-6-U	DG-6-U
19	Combustion air blower	MN 302	MN 302	MN 402
20	Burner control device	ESA ESTRO	ESA ESTRO	ESA ESTRO
21	Thermocouple	"J"	"J"	"J"
22	Thermoregulator	ESA-TARC	ESA-TARC	ESA-TARC

## FLOW CHART (MODULATING)

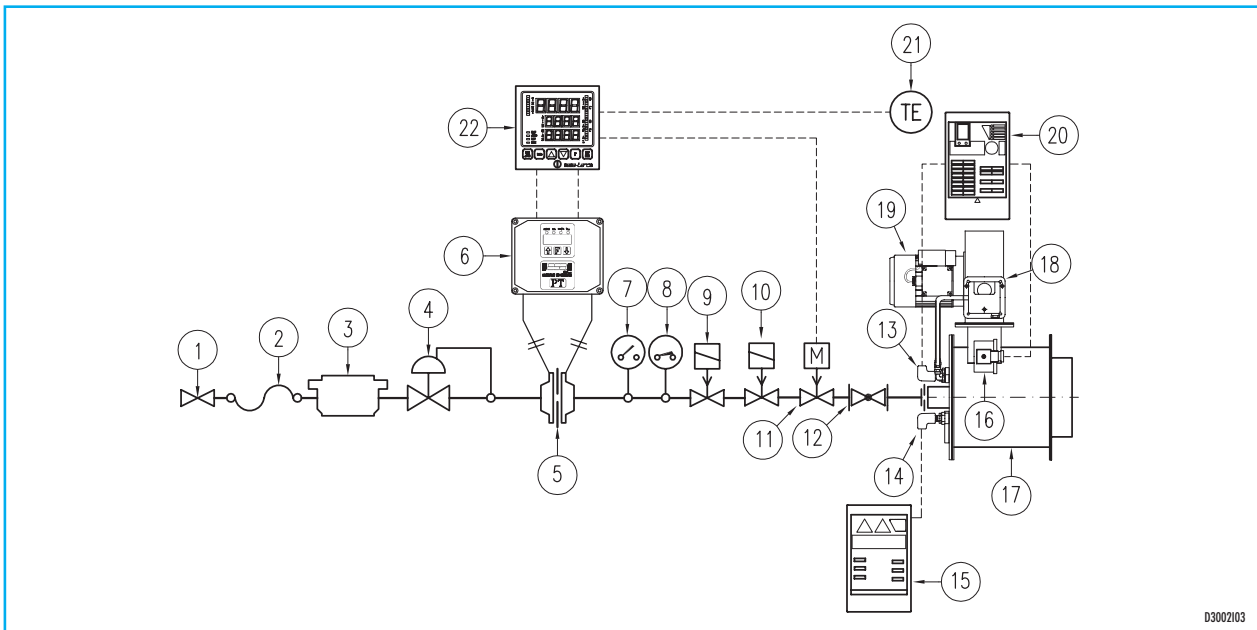

D3002103

POS.	Model identification	FC-5	FC-10	FC-15
1	Gas ball valve	8RSO/T ø1"	12RSO/T ø1.1/2"	12RSO/T ø1.1/2"
2	Flexible connector	8FN ø1"	12FN ø1.1/2"	12FN ø1.1/2"
3	Gas filter	"G" ø1"	"G" ø1.1/2"	"G" ø1.1/2"
4	Reducing regulator	SR-6 ø3/4"	SR-8 ø1"	SR-12 ø1.1/2"
5	Orifice flow meter	8POP-U-S	12POP-U-S	12POP-U-S
6	Flow indicator	ESA PT	ESA PT	ESA PT
7	Low pressure gas limit switch	DG-50-U	DG-50-U	DG-50-U
8	High pressure gas limit switch	DG-500-U	DG-500-U	DG-500-U
9	Rapid opening safety solenoid valve	VM-R3 ø1"	VM-R4 ø1.1/2"	VM-R4 ø1.1/2"
10	Slow opening safety solenoid valve	VM-L3 ø1"	VM-L4 ø1.1/2"	VM-L4 ø1.1/2"
11	Motorized gas adjuster	8GTV ø1"	12GTV ø1.1/2"	12GTV ø1.1/2"
12	Gas adjuster	8VL-2R-CMAP ø1"	12VL-2R-CMAP ø1.1/2"	12VL-2R-CMAP ø1.1/2"
13	Flame rod	WAND	WAND	WAND
14	Spark electrode	WAND	WAND	WAND
15	Ignition transformer	TRAFO	TRAFO	TRAFO
16	UV-scanner with housing	UV2-CHLG2	UV2-CHLG2	UV2-CHLG2
17	Metallic burner	FC-5	FC-10	FC-15
18	Low pressure air limit switch	DG-50-U	DG-50-U	DG-50-U
19	Combustion air blower	MN 302	MN 302	MN 402
20	Burner control device	ESA ESTRO	ESA ESTRO	ESA ESTRO
21	Thermocouple	"J"	"J"	"J"
22	Thermoregulator	ESA-TARC	ESA-TARC	ESA-TARC

## FLOW CHART (TWO STEPS)

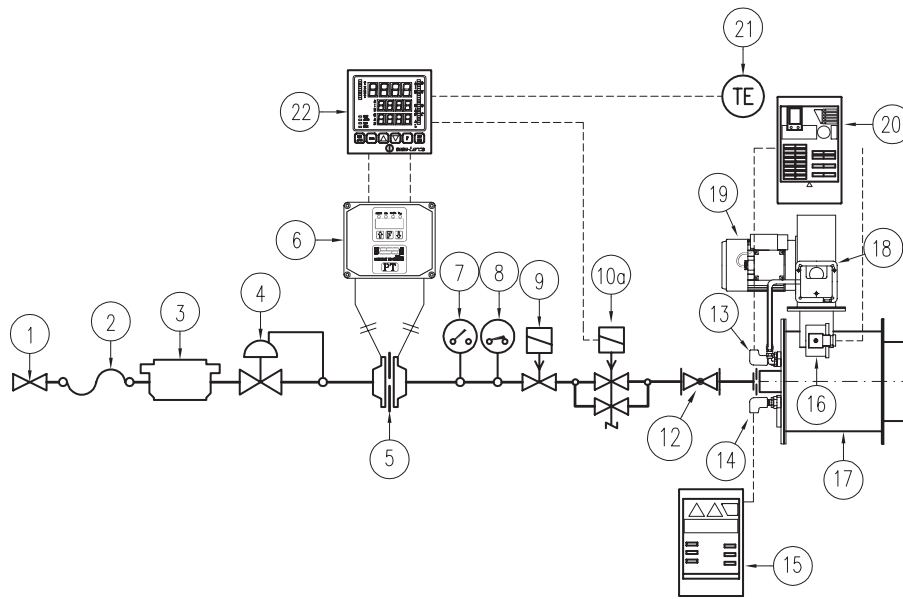

D3002103

POS.	Model identification	FC-5	FC-10	FC-15
1	Gas ball valve	8RSO/T ø1"	12RSO/T ø1.1/2"	12RSO/T ø1.1/2"
2	Flexible connector	8FN ø1"	12FN ø1.1/2"	12FN ø1.1/2"
3	Gas filter	"G" ø1"	"G" ø1.1/2"	"G" ø1.1/2"
4	Reducing regulator	SR-6 ø3/4"	SR-8 ø1"	SR-12 ø1.1/2"
5	Orifice flow meter	8POP-U-S	12POP-U-S	12POP-U-S
6	Flow indicator	ESA PT	ESA PT	ESA PT
7	Low pressure gas limit switch	DG-50-U	DG-50-U	DG-50-U
8	High pressure gas limit switch	DG-500-U	DG-500-U	DG-500-U
9	Rapid opening safety solenoid valve	VM-R3 ø1"	VM-R4 ø1.1/2"	VM-R4 ø1.1/2"
10a	Two-step safety solenoid valve	VM-R3-2REG	VM-R4-2REG	VM-R4-2REG
12	Gas adjuster	8GAF8 ø1"	12GAF12 ø1.1/2"	12GAF12 ø1.1/2"
13	Flame rod	WAND	WAND	WAND
14	Spark electrode	WAND	WAND	WAND
15	Ignition transformer	TRAFO	TRAFO	TRAFO
16	UV-scanner with housing	UV2-CHLG2	UV2-CHLG2	UV2-CHLG2
17	Metallic burner	FC-5	FC-10	FC-15
18	Low pressure air limit switch	DG-50-U	DG-50-U	DG-50-U
19	Combustion air blower	MN 302	MN 302	MN 402
20	Burner control device	ESA ESTRO	ESA ESTRO	ESA ESTRO
21	Thermocouple	"J"	"J"	"J"
22	Thermoregulator	ESA-TARC	ESA-TARC	ESA-TARC

## DIMENSIONS

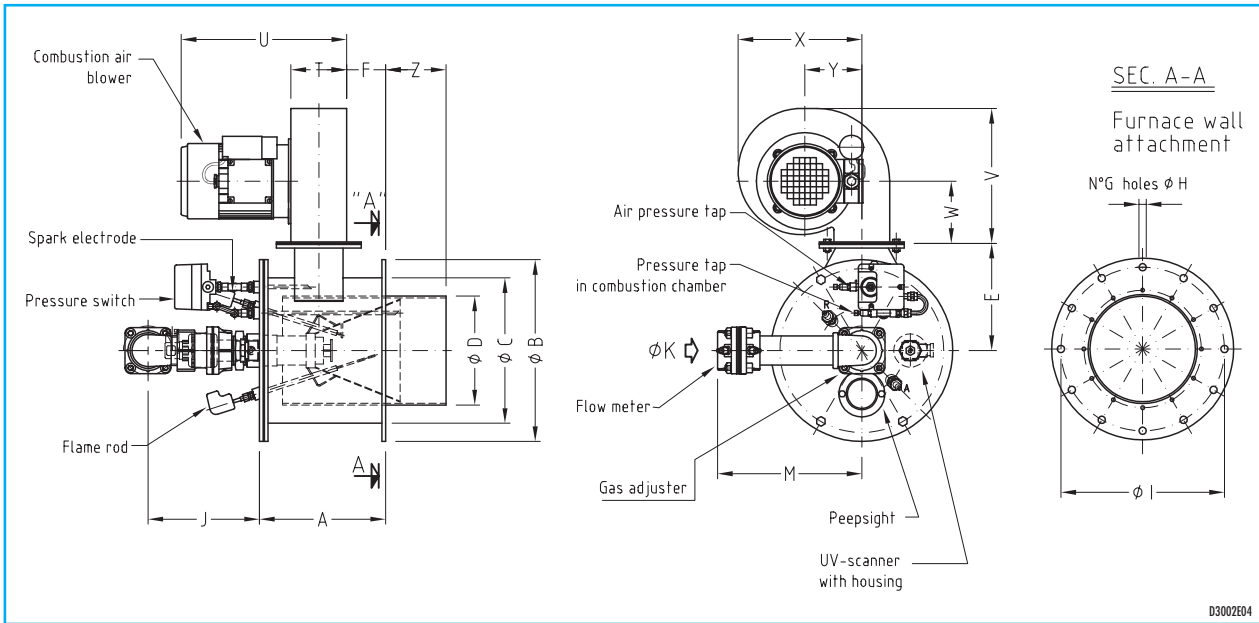

D3002E04

Dimensions	Burner FC-5	Burner FC-10	Burner FC-15
A mm	186	208	258
ø B mm	250	300	360
ø C mm	196	244	294
ø D mm	140	180	230
E mm	149.5	179.5	234.5
F mm	87	64	96
No. G holes	8	12	6
ø H mm	9	12	11
ø I mm	225	270	330
J mm	88	184	121
ø K bsp	G - 1"	G - 1.1/2"	G - 1.1/2"
M mm	295	240	230
T mm	94	92	92
U mm	270	273	305
V mm	223	220	223
W mm	100	100	100
X mm	200	204	204
Y mm	94	94	94
Z mm	47	100	100



NOTE: Based on the company's policy aimed at a continuous improvement on product quality, ESA-PYRONICS reserves the right to bring changes to the technical characteristics of this device without previous notice. Our catalog updated to the latest version is available on our web site [www.esapyronics.com](http://www.esapyronics.com) and it is possible to download modified documents

WARNING: When operating, this combustion system can be dangerous and cause harm to persons or damage to equipment. Every burner must be provided with a protection device that monitors the combustion. The installation, adjustment and maintenance operations should only be performed by trained and qualified personnel.