

Burners



Pilot Heads

BTC & BTSA (E3121 rev. 01 - 06/09/2010)



GENERAL WARNINGS:



■ All installation, maintenance, ignition and setting must be performed by qualified staff, respecting the norms present at the time and place of the installation.

■ To avoid damage to people and things, it is essential to observe all the points indicated in this handbook. The reported indications do not exonerate the Client/User from observing general or specific laws concerning accidents and environmental safeguarding.

■ The operator must wear proper DPI clothing (shoes, helmets...) and respect the general safety, prevention and precaution norms.

■ To avoid the risks of burns or high voltage electrocution, the operator must avoid all contact with the burner and its control devices during the ignition phase and while it is running at high temperatures.

■ All ordinary and extraordinary maintenance must be performed when the system is stopped.

■ To assure correct and safe use of the combustion plant, it is of extreme importance that the contents of this document be brought to the attention of and be meticulously observed by all personnel in charge of controlling and working the devices.

■ The functioning of a combustion plant can be dangerous and cause injuries to persons or damage to equipment. Every burner must be provided with certified combustion safety and supervision devices.

■ The burner must be installed correctly to prevent any type of accidental/undesired heat transmission from the flame to the operator or the equipment.

■ The performances indicated in this technical document regarding the range of products are a result of experimental tests carried out at ESA-PYRONICS. The tests have been performed using ignition systems, flame detectors and supervisors developed by ESA-PYRONICS. The respect of the above mentioned functioning conditions cannot be guaranteed if equipment, which is not present in the ESA-PYRONICS catalogue, is used.

DISPOSAL:



To dispose of the product, abide by the local legislations regarding it.

GENERAL NOTES:



■ In accordance to the internal policy of constant quality improvement, ESA-PYRONICS reserves the right to modify the technical characteristics of the present document at any time and without warning.

■ It is possible to download technical sheets which have been updated to the latest revision from the **www.esapyronics.com** website.

CERTIFICATIONS:



EN746-2

The products manufactured by ESA-PYRONICS have been created in conformity to the **UNI EN 746-2** Norms: Equipment for industrial thermal process - Part 2: Safety requirements for combustion and the movement and treatment of combustible elements. This norm is in harmony with the Machine Directive **98/37/CE**. It is certified that the products in question respect all the requirements prescribed by the above mentioned Norms and Directives. These have been designed, produced, controlled and tested in accordance to the company's internal procedures for quality control, certified in conformity with the **UNI EN ISO 9001** Norm by DNV Italia s.r.l.



The products conform to the Russian market requirements according to the **GOST** and **GOSGORTEKHADZOR** certification.

CONTACTS / SERVICE:



Headquarters:

Esa s.r.l.
Via Enrico Fermi 40
24035 Curno (BG) - Italy
Tel +39.035.6227411
Fax +39.035.6227499
esa@esacombustion.it

International Sales:

Pyronics International s.a.
Zoning Industriel, 4ème rue
B-6040 Jumet - Belgium
Tel +32.71.256970
Fax +32.71.256979
marketing@pyronics.be

www.esapyronics.com

The BTC & BTSA series identifies a family of premix burners, mainly used for the ignition of burners with large capacities. The special shape of the combustion head guarantees excellent flame retention, resistance to thermal stress and long duration.

APPLICATIONS

- Main burner pilot ignition.
- Billete heating.
- Furnaces for glass.
- Casting burners.



F3121103

CHARACTERISTICS

GENERAL:

- | | |
|-----------------------------|-----------------|
| ■ Capacity: | from 2 to 15kW |
| ■ Fuel gas: | CH4/LPG/Propane |
| ■ Ignition/detection: | monoelectrode |
| ■ Max. working temperature: | 1100°C |
| ■ Excellent flame stability | |
| ■ Inlet air pressure: | 36÷72 mbar |
| ■ Inlet gas pressure: | 20÷100 mbar |

MATERIAL COMPOSITION:

- | | |
|--------------------|---------------------|
| ■ Combustion head: | AISI310 |
| | Alumina 96% ceramic |
| ■ Flame tube: | AISI304/INCOLOY 601 |



F3121104

CAPACITY PARAMETERS

Paired with the MM or FLOWMIXER mixer series, the BTC & BTSA pilot heads develop their maximum capacity at about 15mbar of premix pressure.

The burners remain stable with mix pressures ranging from 10 to 20 mbar.

Model	Max. capacity [kW]	Flame length [mm]	Ignition/detection electrode
42BTC	2	30÷40	42CWFR
64BTC	5	50÷70	64CWFR
86BTC	10	80÷100	86CWFR
64BTSA	5	50÷70	10MM
86BTSA	10	80÷100	10MM
108BTSA	15	100÷120	6EN/10MM

WARNINGS

- - For all applications at low temperatures (upto 750°C) the burner ignition and the gas fuel solenoid valve command must be carried out via a certified burner control device.
- - To avoid any possible damage to the burners, make sure that the air is not preheated or foul due to combustion products, oils, solvents or other. To avoid these phenomena, it is preferable to install the blower or suction duct outside the premises and far from exhaust pipes, or else to fit filters upstream the premix group. If the combustion air should come from the compressed air lines, NEVER exceed the maximum allowable pressure Pmax=360 [mm].
- - After installation, check that the power feeding lines are connected correctly. Before switching the burner on check that the combustion air and fuel pressure values are correct.
- - The burner must only function within the indicated power ranges. Working with lower or higher power may compromise the functioning and life span of the burner, in which case the general guarantee conditions will automatically expire and ESA-PYRONICS will not be held liable for possible damage caused to persons and objects.
- - Should there be disturbances with other devices during the burner start-up phase, use an anti-disturbance filter for the high voltage cable (hv) connection to the ignition electrode.
- - Avoid burner ignition close to each other so as not to heat the ignition command system devices (solenoid valves and transformers). Prewash time lapse + first safety time lapse + min. of 5 sec. = time lapse between one ignition and another. (However, do not attempt more than 2 ignitions during a 30sec. time lapse).
- - Make sure the power supply is TURNED OFF when intervening on the burner and its devices. In case of burner malfunctioning, follow the indications in the 'Maintenance' chapter of the present manual or contact ESA-PYRONICS assistance.
- - Any modification or repair done by third parties can compromise the application safety and automatically cause the general warrantee conditions to expire. Contact ESA-PYRONICS assistance.

INSTALLATION

The BTC & BTSA series pilot heads are supplied with with threaded fastening connectors. It is possible to create fastening applications according to specific needs. To avoid foreign material from obstructing the burner flame tube and condensation phenomena causing ignition and detection problems, we do not recommend assembling with the flame pointing upwards. For the mixing pipe connection, the use of flexible extensible connectors is advisable:

the connections between the burner and mixer must have at least the same outlet diameter as the mixer. Do not place valves nor any type of restrictions on the mixture pipeline. For the BTC-FR/X (models with variable lengths and sliding fixing couplings), check that the pilot burner outlet is not placed in direct contact with the main burner flame. This is important to preserve the integrity of the metallic pipe.

START - UP - SETTING

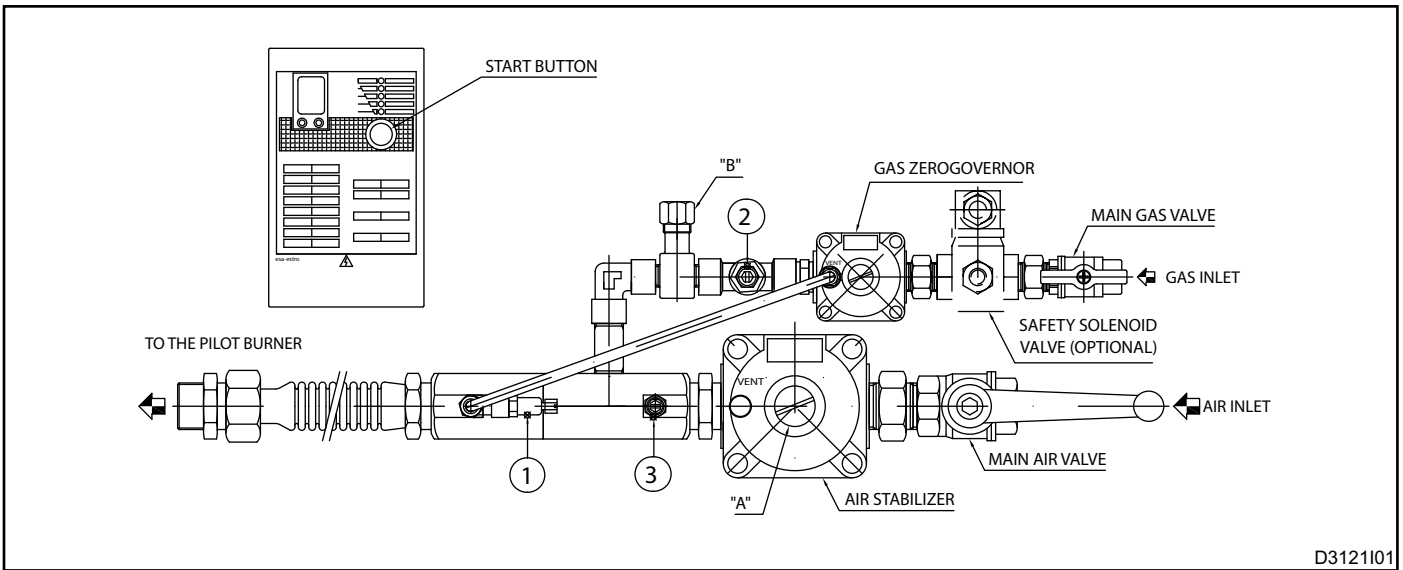

D3121101

The procedures indicated in the following chapter must be carried out by expert technicians. The non-observance of the instructions given can provoke dangerous conditions

- 1 - Check the safety solenoid valve (if present), ignition electrode and flame control electrical connections.
- 2 - Check for an air minimum feeding pressure of 36mbar and a gas minimum feeding pressure 20mbar.
- 3 - Open the main air valve.
- 4 - Open the air stabilizer cap ("A").
- 5 - Adjust the spring regulation (screwing on or unscrewing the regulation plug) until reaching a mix-pressure of 10÷15 mbar on the pressure plug (**pos. 01**) with "burner OFF". Screwing on increases the pressure/unscrewing decreases the pressure.
- 6 - The gas pressure when the burner is off (**pos. 02**) must be negative. The inlet air pressure (**pos. 03**) must correspond to 40÷50 mbar.
- 7 - Open the main gas valve.
- 8 - Switch the burner on with the start button found on the flame control device, opening the gas throttle valve nee-

dle ("B") very slowly, during ignition (repeat the step until you see a stable flame on the pilot burner).

9 - Adjust the gas flow via the gas throttle valve screw cap to reach the highest detection value on the flame control.

10 - To obtain an excellent flame regulate the gas flow in the following conditions:

A - Excess of air: short blue flame that disappears into the pilot tube (low detection).

B - Right ratio: light blue tense flame with a good detection (40÷60 μA).

C - Excess of gas: long blue-green flame near flame detachment (low detection).

11 - Once the right regulation has been reached, check for a mix-pressure of 15÷20 mbar (**pos.01**) with "burner on". Adjust the air stabilizer screw if necessary.

12 - Turn off the burner and make sure it starts again, checking for several positive ignitions.

13 - Make sure there is pressure downstream the zero-governor (**pos.02**). The right value is similar to the mix-pressure value that is set in the air regulation (it can be adjusted by adjusting the zero-governor spring position).



F3121105

Excess of air



F3121106

Correct ratio



F3121107

Exces of gas

CAPACITY DIAGRAM

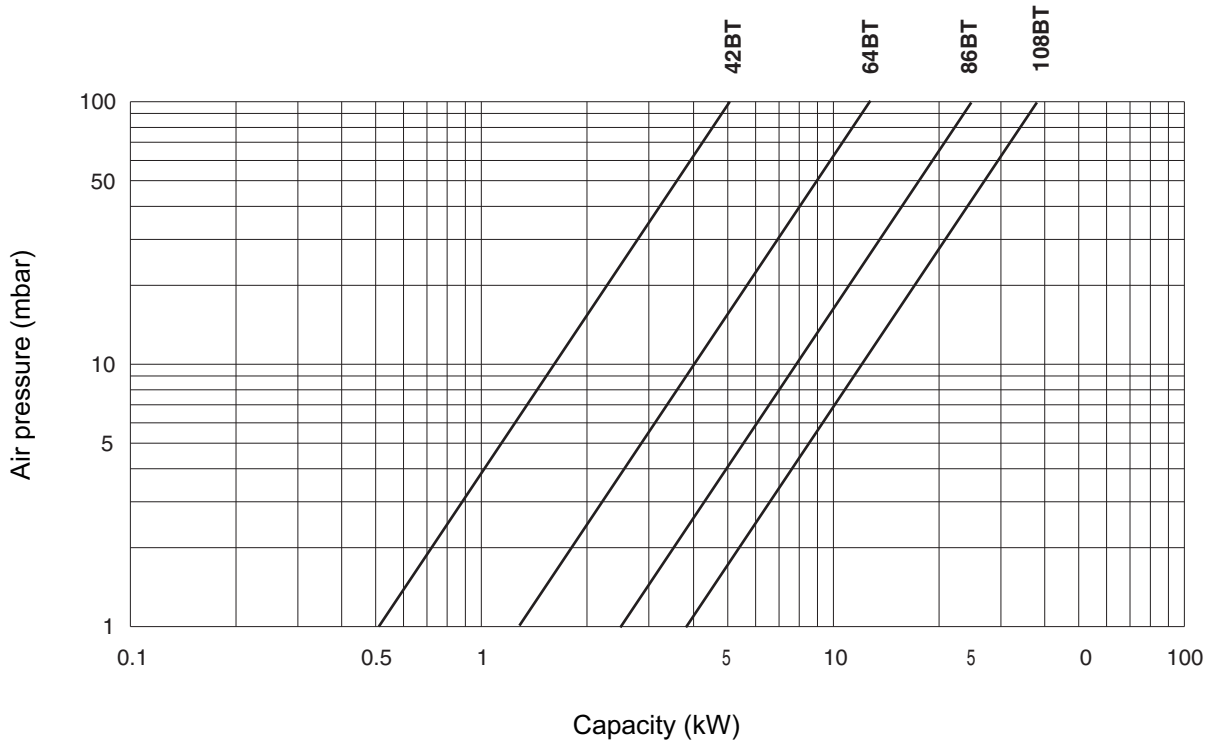

G3121101

GENERAL MAINTENANCE PLAN

Operation	Typr	Advised time	Notes
High voltage electrode connection	O	annual	Check integrity of outer plastic and oxidation of internal connector and of the electrode terminal
Ignition electrode and head	O	annual	replace in case the Kantal terminal is worn or if the combustion head is damaged
Burner setting	O	annual	repeat all the steps in the "START UP AND SETTING" section on page 6

O= Ordinary
E= Extraordinary

EXTRAORDINARY MAINTENANCE - BTC & 108BTSA-FR/X PILOT HEADS

IGNITION ELECTRODE REPLACEMENT

- 1 - Check that the burner control device power is off.
- 2 - Disconnect the HV cable, disconnecting the insulating connector from the electrode (**pos. 01**).
- 3 - Unscrew the spark plug (**pos. 02**) and extract it from

the threaded seat.

- 4 - Insert the spare spark plug screwing it on properly again.

- 5 - Check that the insulator connector is properly connected (**pos. 01**).

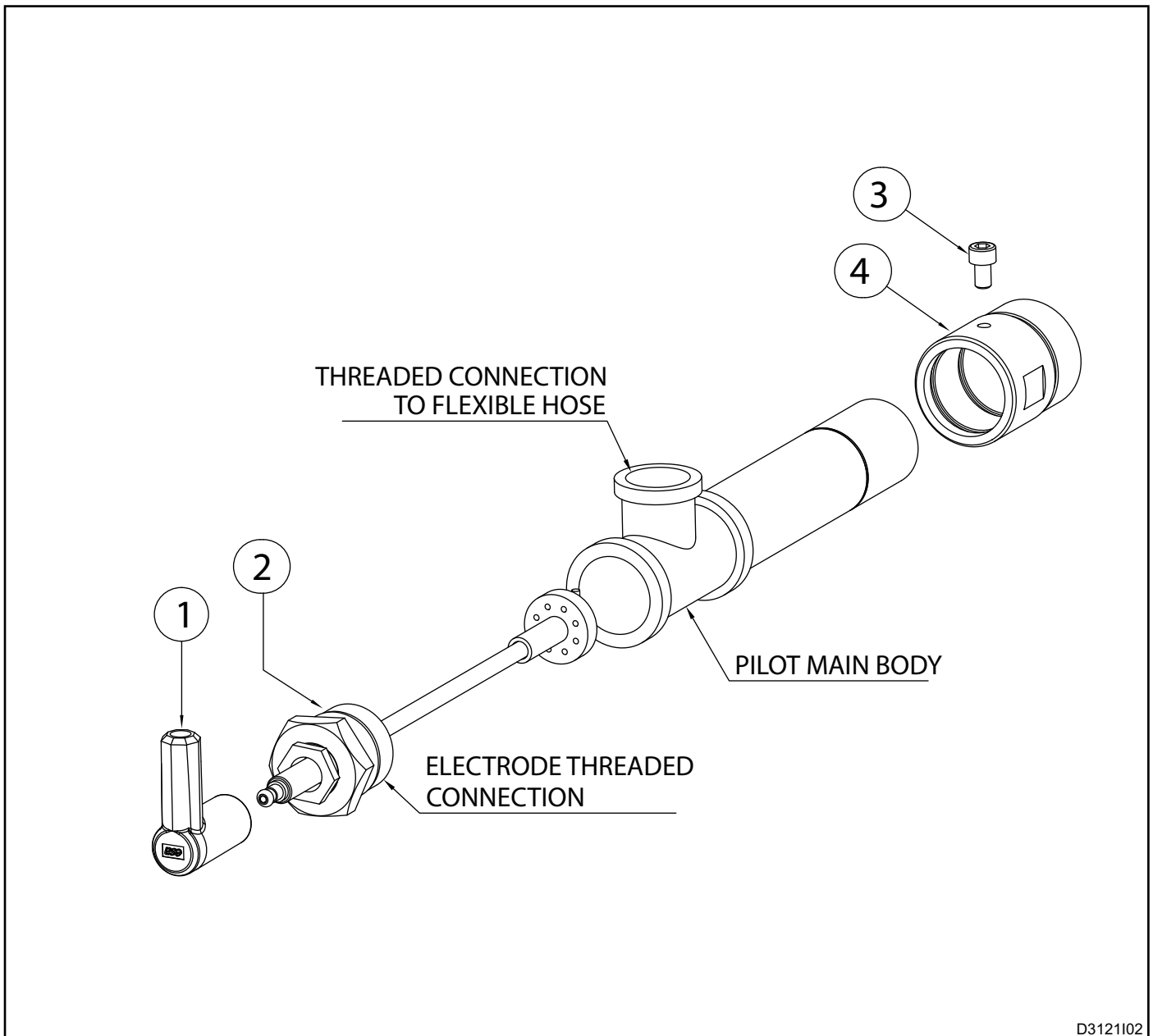

D3121102

ORDINARY MAINTENANCE - 64/86 BTSA PILOT HEADS

IGNITION ELECTRODE REPLACEMENT

- 1 - Check that the burner control device power is off.
- 2 - Disconnect the HV cable, disconnecting the insulating connector from the electrode (**pos. 01**).
- 3 - Unscrew the block screw (**pos. 03**) and extract the pilot burner from the fastening connection (**pos. 04**).
- 4 - Unscrew the upper connection (**pos. 02**) and completely extract the electrode from the pilot burner.
- 5 - Insert the spare electrode and screw on the connection completely.
- 6 - Place the pilot burner in the correct position, tightening the appropriate screw (**pos. 03**).
- 7 - Check that the insulator connector is properly connected.

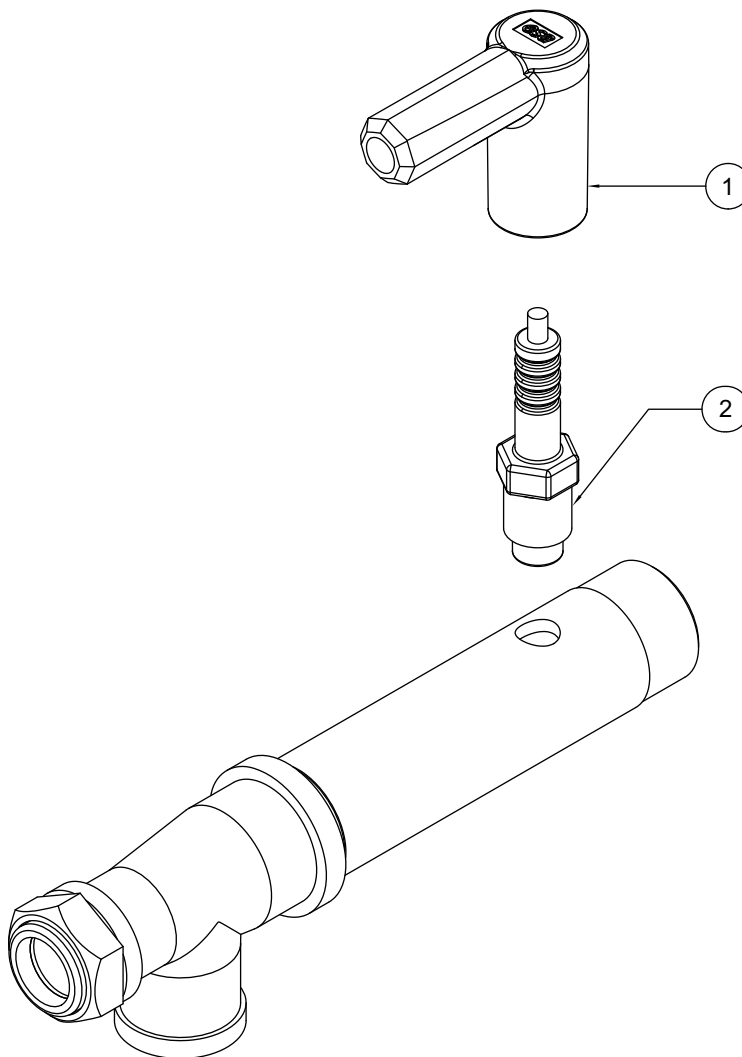

D3121I03

OVERALL DIMENSIONS - BTC-FR

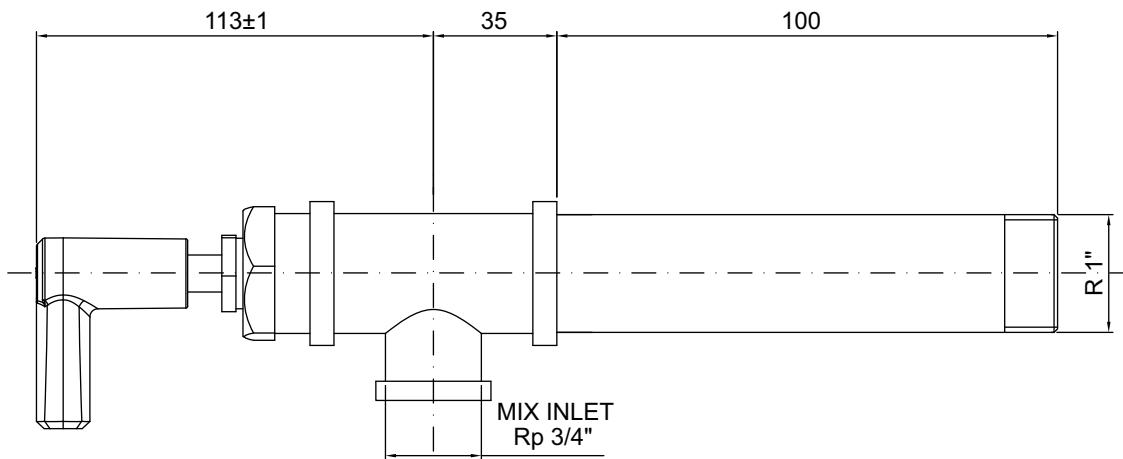
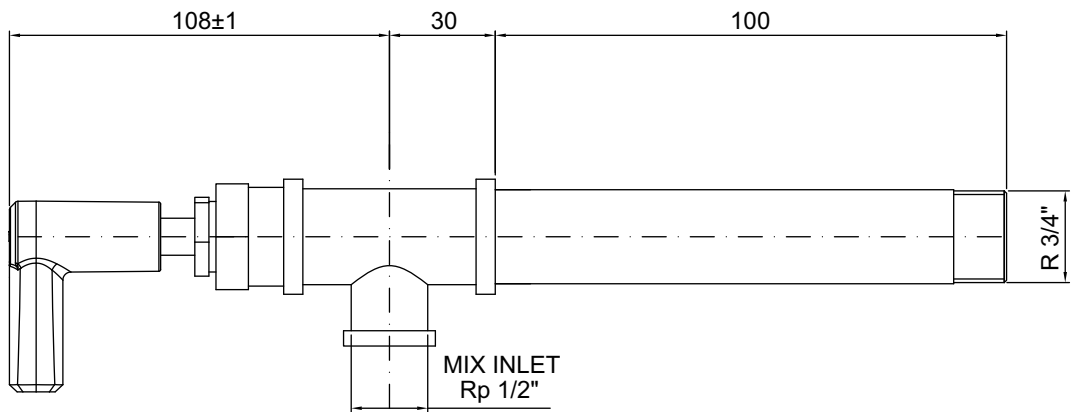
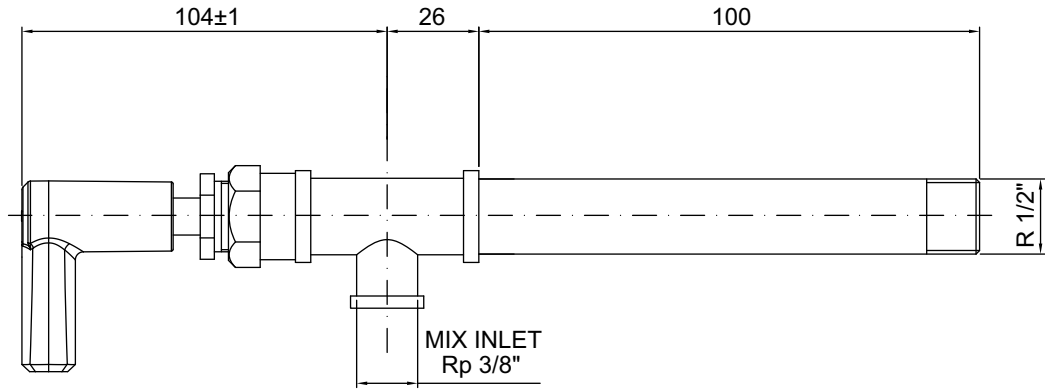

D3121104

OVERALL DIMENSIONS - BTC-FR/X

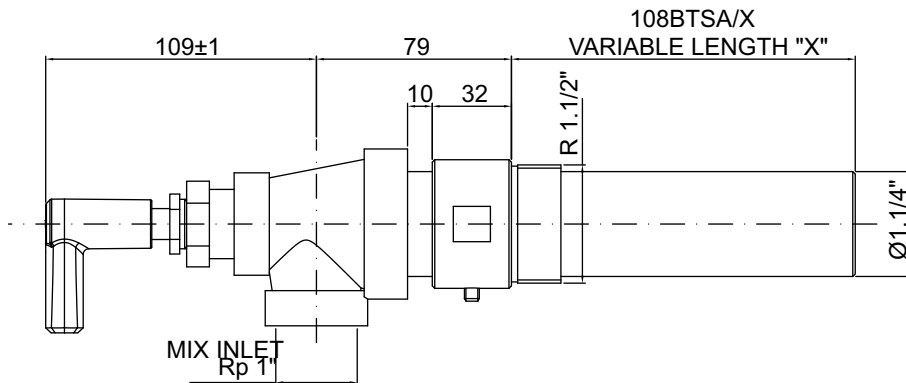
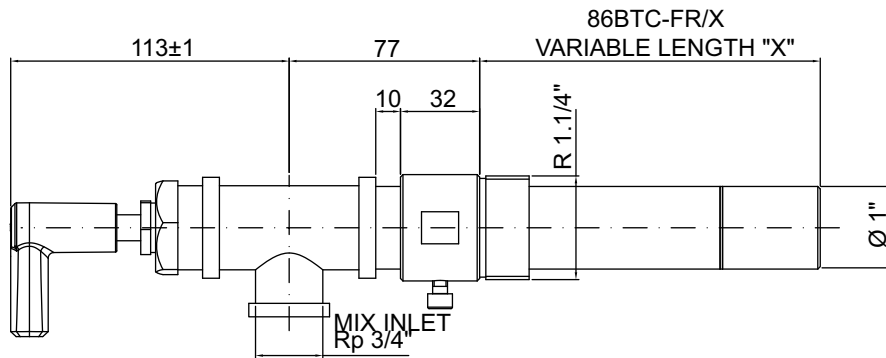
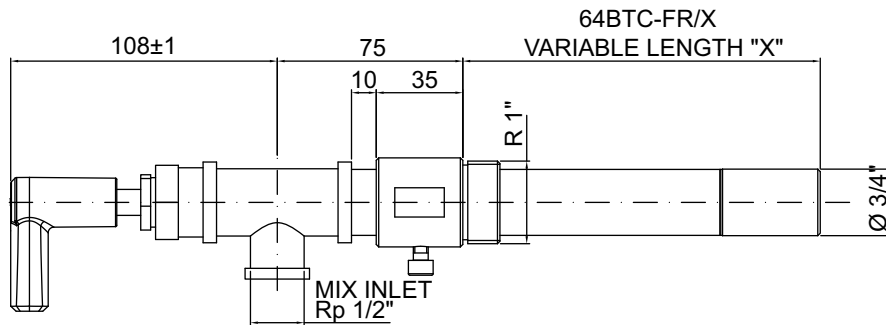
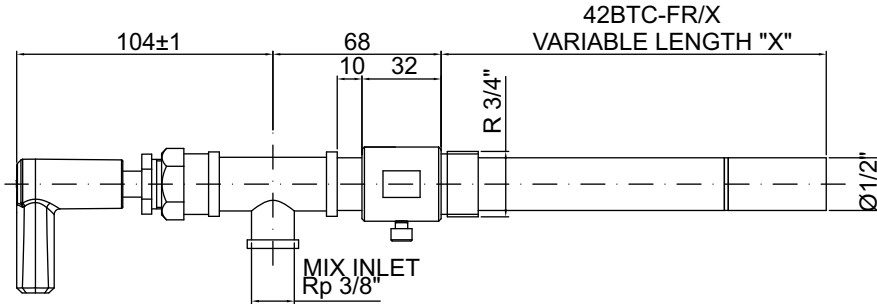

D3280109

OVERALL DIMENSIONS - BTSA

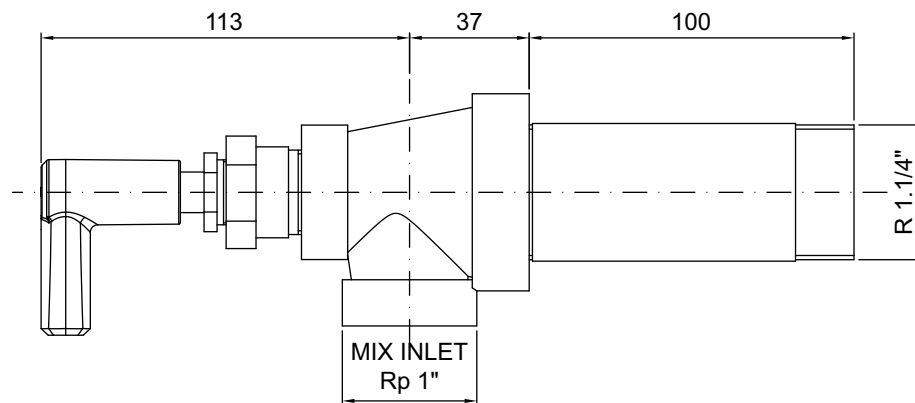
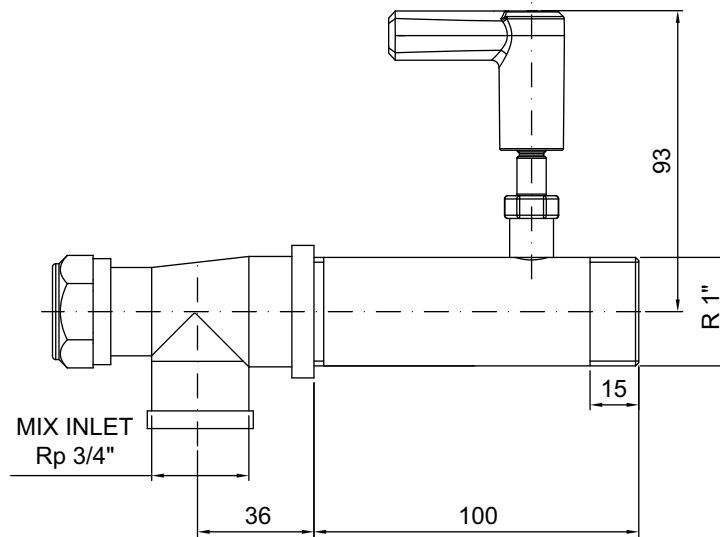
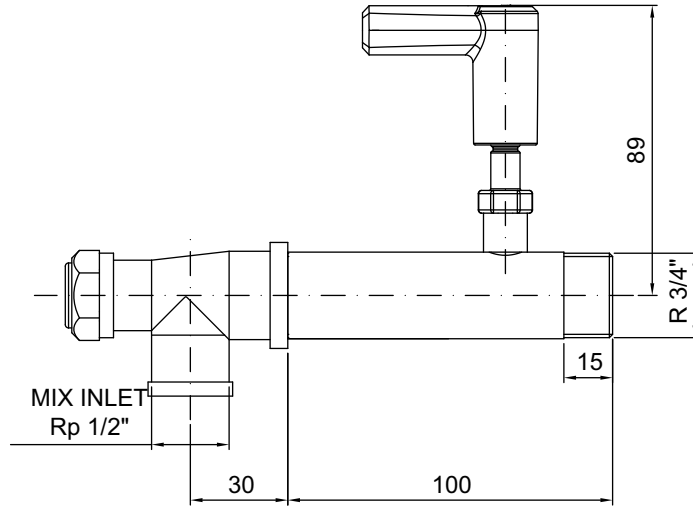

D3280109