

# EXCESS AIR BURNERS XNM SERIES

## FEATURES

- Mixer: cast iron G25
- Plate: cast iron G25
- Air tube: AISI304
- Pre-heated air: up to 450°
- Suitable for different types of gas: CH<sub>4</sub>/L.P./propane/etc
- Standard refractory block, max. temp.: 1750°C
- Capacity range: 16 to 1700 kW
- Excess air for all models: over 800%
- Excellent flame stability: excess air  
excess fuel  
on ratio firing
  
- Low NO<sub>x</sub> level.
- Wall mounting flanges to fasten the block holder to the furnace shell are threaded to allow for positioning of accessories: pilot burner, flame detectors (electrodes or UV scanners), peepsight.
- Separated air and gas inlets, mixing at discharge point, no flashback.

## APPLICATIONS

- Annealing furnaces.
- Air heaters.
- Heat treat furnaces.
- Incinerators.
- Stress Relieving Furnaces.
- Brick furnaces.
- Ladle and crucible melting reheating.

## DESCRIPTION

Excess air burners are intermediate flame length, nozzle mixing types designed for 800% excess air. A unique design and stepped tunnel burner blocks produce excellent flame stability at all firing rates. Excess air systems use a constant air flow and "on ratio" combustion at high fire. Only the gas flow is reduced for fuel input turndown. The total volume of hot gases and velocity remains nearly constant at all firing rates. Furnace pressure, turbulence and heat

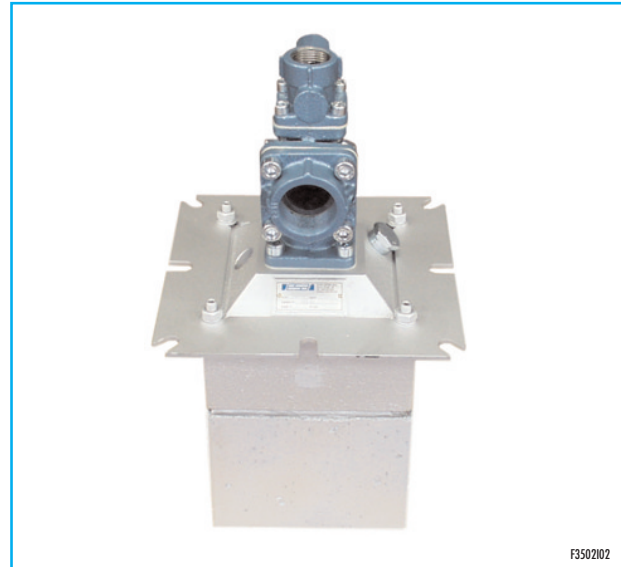

F3502102

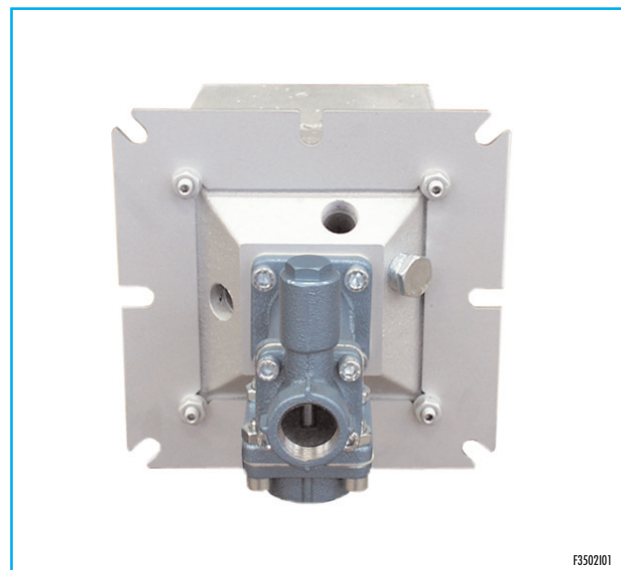

F3502101

transfer rates are uniform. Excess air burners are variable temperature air heaters. At high fire flame temperatures may be about 1500°C or higher. As fuel only is decreased, exit gas temperatures drop to as low as 300°C with 800% excess air.



**Headquarters**  
Esa S.r.l.  
Via E. Fermi 40 I-24035 Curno (BG) - Italy  
Tel. +39.035.6227411 - Fax +39.035.6227499  
esa@esacombustion.it - www.esapyronics.com

**International Sales**  
Pyronics International S.A./N.V.  
Zoning Ind., 4ème rue B-6040 Jumet - Belgium  
Tel +32.71.256970 - Fax +32.71.256979  
marketing@pyronics.be

## INSTALLATION

XNM burners are usually mounted on the wall. Other mounting positions are not recommended; specify if other mounting positions are absolutely necessary when ordering.

When they are used, the furnace refractory should be set to leave some room on all sides of the block. This space should be packed with flexible, refractory, ceramic fibre protected by 20 mm of

refractory concrete on all sides to allow for expansion of the walls (see technical note). Flexible connectors are recommended for air and gas connections at the burner to allow slight movement or misalignment of piping and are required when pre-heated air is involved. Air and gas connections are Pyronics' standard threaded, or welding flanged type. They may rotate by 90°.

## IGNITION AND FLAME DETECTION

XNM burners must be ignited at low fire with a PBST blast pilot.

Pilot burner must be switched off after ignition of main burner thus flame detection must be done by counterclockwise UV Scanner. For low capacity burners direct spark ignition may be done through DSE

electrodes. In this case UV-2 ultraviolet scanners must be used.

Flame detection systems are required on all burners with furnace temperatures below 750°C.

Catalog No.	Pilot burner ignition		Accensione con elettrodo	
	Ignition	Detection	Ignition	Detection
10XNM	P64PBST	UV-2 / 6EN-150 *	DSE-1	UV-2
12XNM	P64PBST	UV-2 / 6EN-150 *	DSE-1	UV-2
16XNM	P64PBST	UV-2 / 6EN-150 *	DSE-1	UV-2
20XNM	P64PBST	UV-2 / 6EN-300 *	DSE-1	UV-2
24XNM	P64PBST	UV-2 / 6EN-300 *	DSE-1	UV-2
32XNM	P86PBST	UV-2 / 6EN-300 *	(not available)	(not available)
48XNM	P86PBST	UV-2 / 6EN-300 *	(not available)	(not available)

(\*) In most cases, we suggest you to make flame detection through UV- scanner. In some particular cases, it is possible to use continue pilot burner with detection electrode.

## CAPACITY TABLE

Catalog no.	Excess air operation			On ratio operation				
	Air flow	Gas flow		kW at various air and gas pressures (at burner) (mbar)				
	Nm <sup>3</sup> /h	Max Nm <sup>3</sup> /h	Min Nm <sup>3</sup> /h	1.1	3.3	11	17.6 (¹)	26.4 (²)
10 XNM	71	7.1	0.8	16	23	47	62	73
12 XNM	100	10	1	23	32	64	85	103
16 XNM	200	20	2.2	44	64	129	167	205
20 XNM	283	28.3	3	64	94	185	243	293
24 XNM	425	42.5	5	97	141	281	366	440
32 XNM	850	85	10	193	281	563	733	879
48 XNM	1700	170	19	387	563	1125	1465	1758

## NOTE

- <sup>1</sup> In the highlighted column there are nominal capacities that must be used for a correct sizing of the burner (air pressure: 17.6 mbar)
- <sup>2</sup> Air pressure of burner 25 mbar and gas pressure 10 mbar to develop maximum ratings excess air or "on-ratio".

## FLAME DIMENSIONS TABLE

Model	Flame length mm
10 XNM	220 ÷ 300
12 XNM	220 ÷ 500
16 XNM	270 ÷ 750
20 XNM	320 ÷ 1.000
24 XNM	620 ÷ 1.250
32 XNM	780 ÷ 1500
48 XNM	1220 ÷ 2000

## NOTE:

Flame dimensions are approximate, referred to burners fed with CH<sub>4</sub>, working at stoichiometric ratio, in free air. Values are included in a range: minimum value is referred to burner working at nominal capacity (¹), higher value at maximum capacity (²).

The flame shortens by increasing excess of air (decreasing gas flow rate)

### CAPACITY TABLE

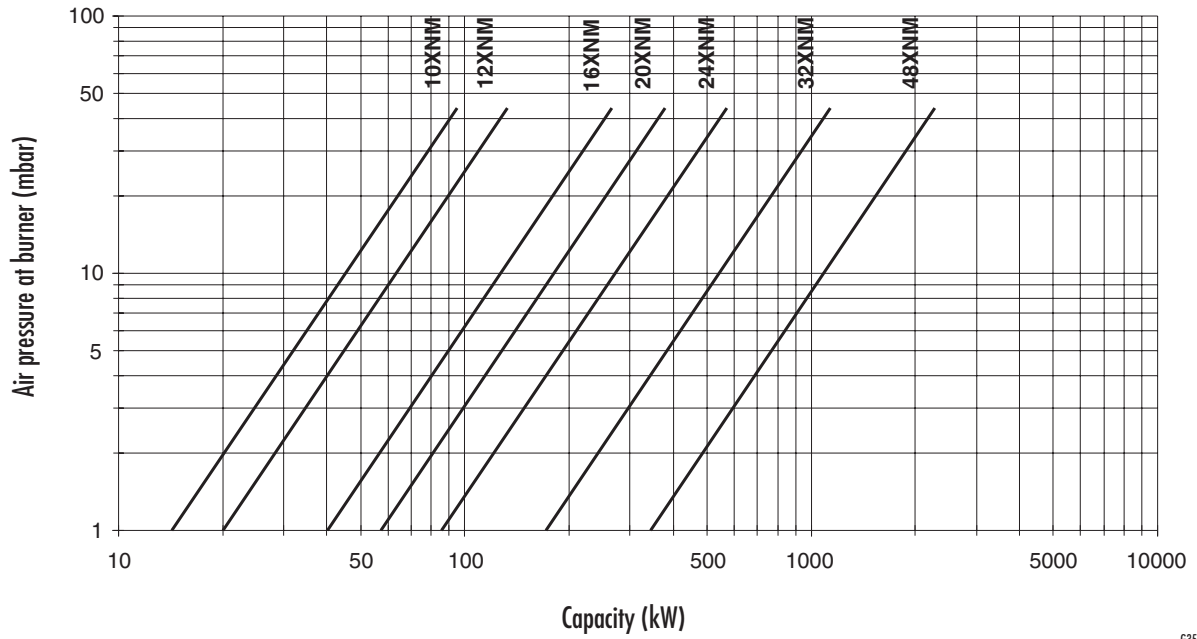

G3502101

### EXCESS AIR AND TEMPERATURE CHART

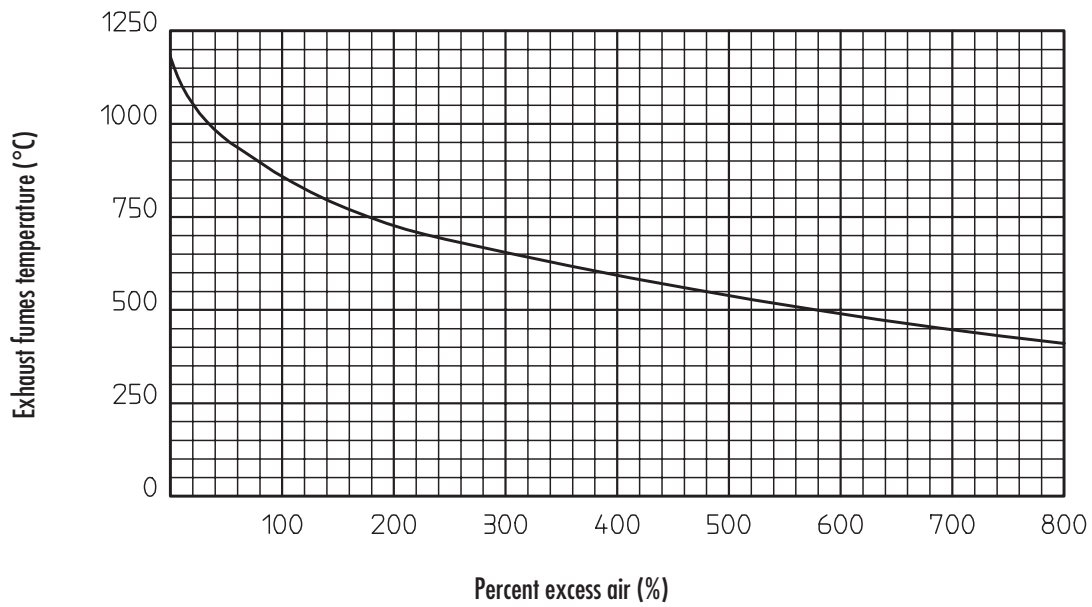

G3502102

FLOW CHART (ON RATIO OPERATION)

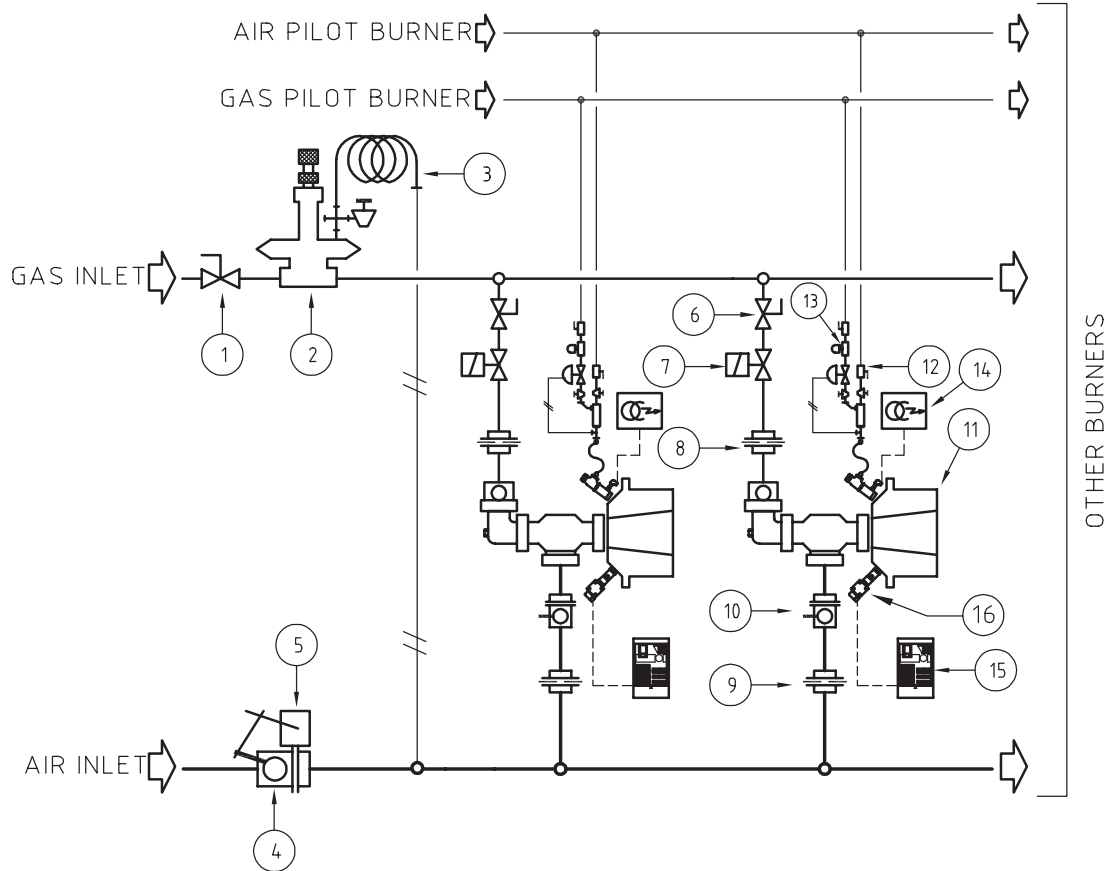

Pos.	Model identification	Pos.	Model identification
1	Gas ball valve	9	Orifice flow meter for $\Delta P$ air
2	Balanced zero regulator	10	Manual air butterfly valve
3	Impulse line	11	Cone-shaped flame burner
4	Motorized air butterfly valve	12	Pilot burner
5	Electric control	13	Pilot burner safety solenoid gas valve
6	Gas ball valve at each burner	14	Ignition transformer
7	Main burner safety solenoid gas valve	15	Flame detection
8	Orifice flow meter for $\Delta P$ gas	16	UV-scanner

D3502/01

FLOW CHART ( EXCESS AIR )

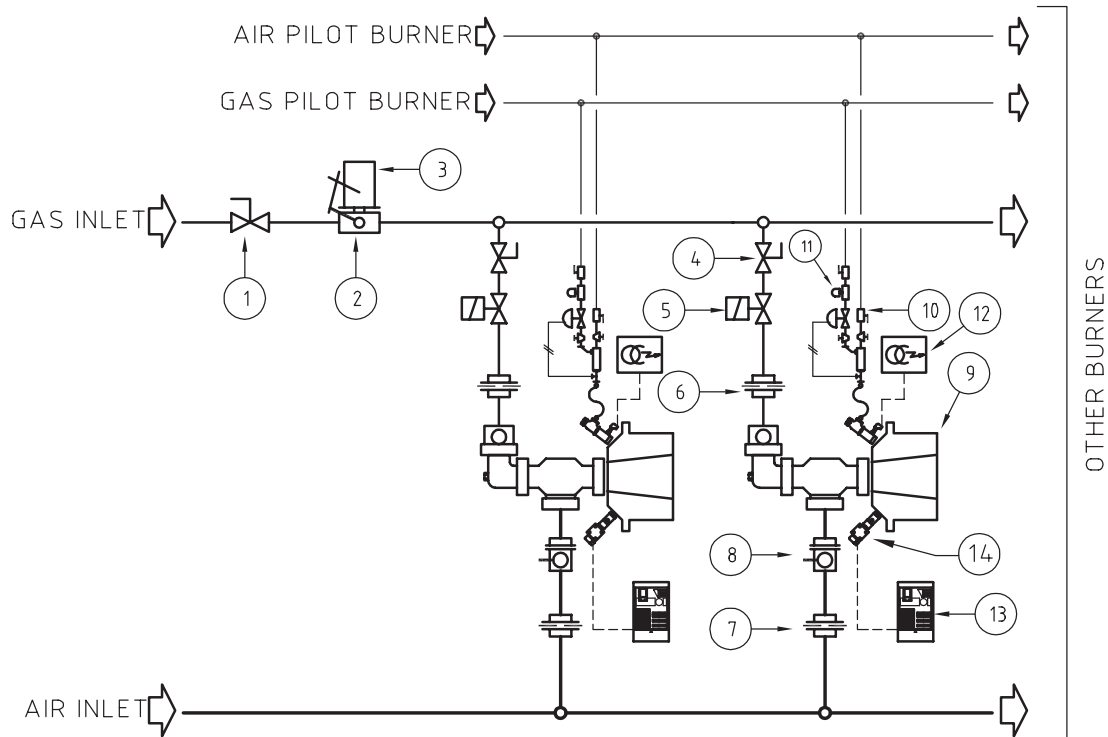

Pos.	Model identification	Pos.	Model identification
1	Gas ball valve	8	Manual air butterfly valve
2	Motorized butterfly air valve	9	Cone-shaped flame burner
3	Electric control	10	Pilot burner
4	Gas ball valve at each burner	11	Pilot burner safety solenoid gas valve
5	Main burner safety solenoid gas valve	12	Ignition transformer
6	Orifice flow meter for $\Delta P$ gas	13	Flame detection
7	Orifice flow meter for $\Delta P$ air	14	UV-scanner

D3502102

## DIMENSIONS

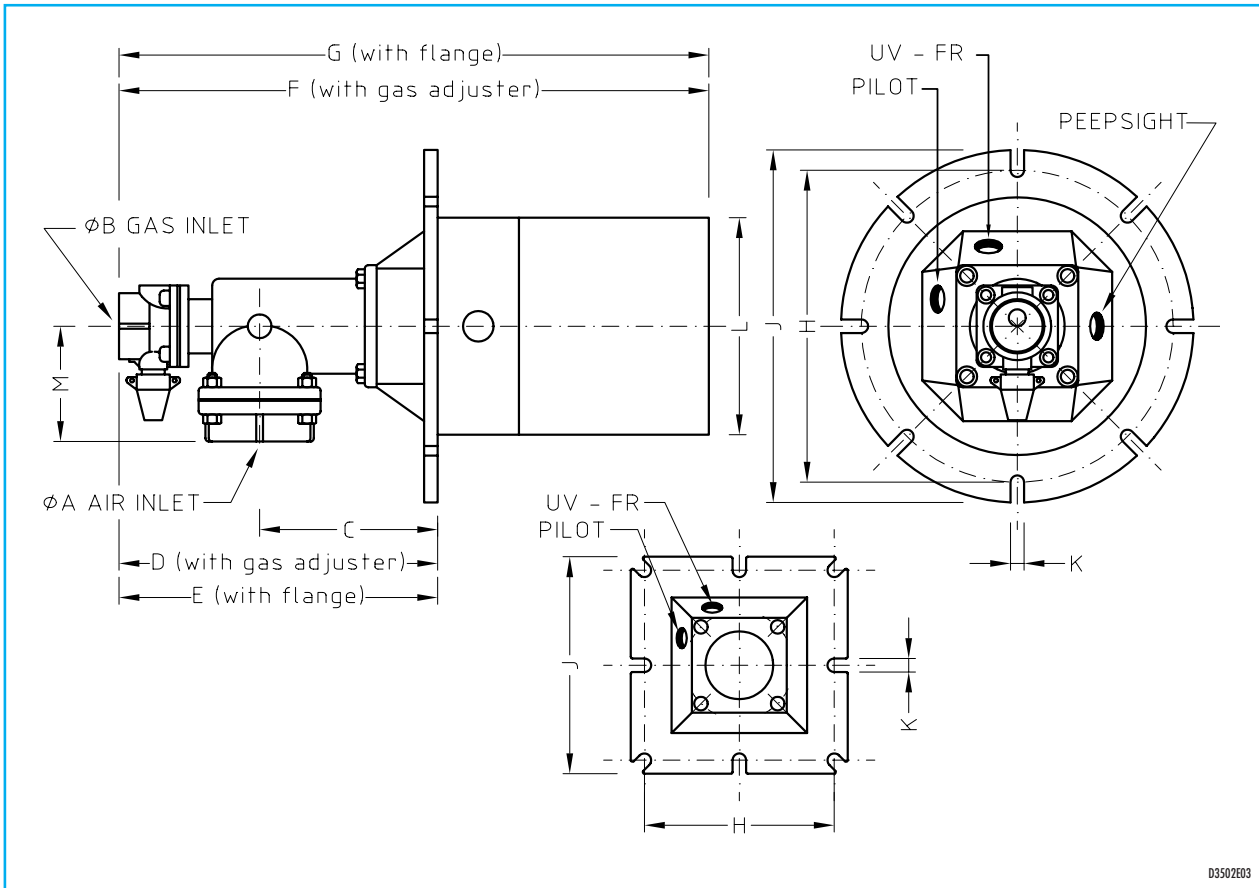

D3502E03

Catalog no.	Ø Pilot	Ø UV-EN	Ø Peep sight	Ø A air	Ø B gas	C mm	D mm	E mm	F mm	G mm	H mm	J mm	K mm	L mm	M mm
10XNM-R	G-3/4"	G-3/4"	G-3/4"	G-1.1/4"	G-1"	121	210	184	438	416	∅ 222	∅ 254	14	∅ 178	79
10XNM-S	G-3/4"	G-3/4"	G-3/4"	G-1.1/4"	G-1"	121	210	184	438	413	∅ 222	∅ 254	14	∅ 178	79
12XNM-R	G-3/4"	G-3/4"	G-3/4"	G-1.1/2"	G-1"	121	210	184	438	413	∅ 222	∅ 254	14	∅ 178	79
12XNM-S	G-3/4"	G-3/4"	G-3/4"	G-1.1/2"	G-1"	121	210	184	438	413	∅ 222	∅ 254	14	∅ 178	79
16XNM-R	G-3/4"	G-3/4"	G-3/4"	G-2"	G-1"	130	210	184	438	413	∅ 222	∅ 254	14	∅ 178	86
16XNM-S	G-3/4"	G-3/4"	G-3/4"	G-2"	G-1"	130	210	184	438	413	∅ 222	∅ 254	14	∅ 178	86
20XNM-R	G-3/4"	G-3/4"	G-3/4"	G-2.1/2"	G-1.1/2"	152	283	260	537	514	∅ 289	∅ 330	16	∅ 203	108
20XNM-S	G-3/4"	G-3/4"	G-3/4"	G-2.1/2"	G-1.1/2"	152	283	260	537	514	∅ 278	∅ 330	16	∅ 229	108
24XNM-R	G-3/4"	G-3/4"	G-3/4"	G-3"	G-1.1/2"	175	283	260	537	514	∅ 289	∅ 330	16	∅ 203	108
24XNM-S	G-3/4"	G-3/4"	G-3/4"	G-3"	G-1.1/2"	175	283	260	537	514	∅ 278	∅ 330	16	∅ 229	108
32XNM-R	G-1"	G-3/4"	G-3/4"	DN100	G-2.1/2"	216	419	355	724	660	∅ 349	∅ 406	16	∅ 298	110
48XNM-R	G-1"	G-3/4"	G-3/4"	DN150	G-3"	229	473	381	803	711	∅ 457	∅ 508	16	∅ 400	148

## ORDERING CODES - BURNER

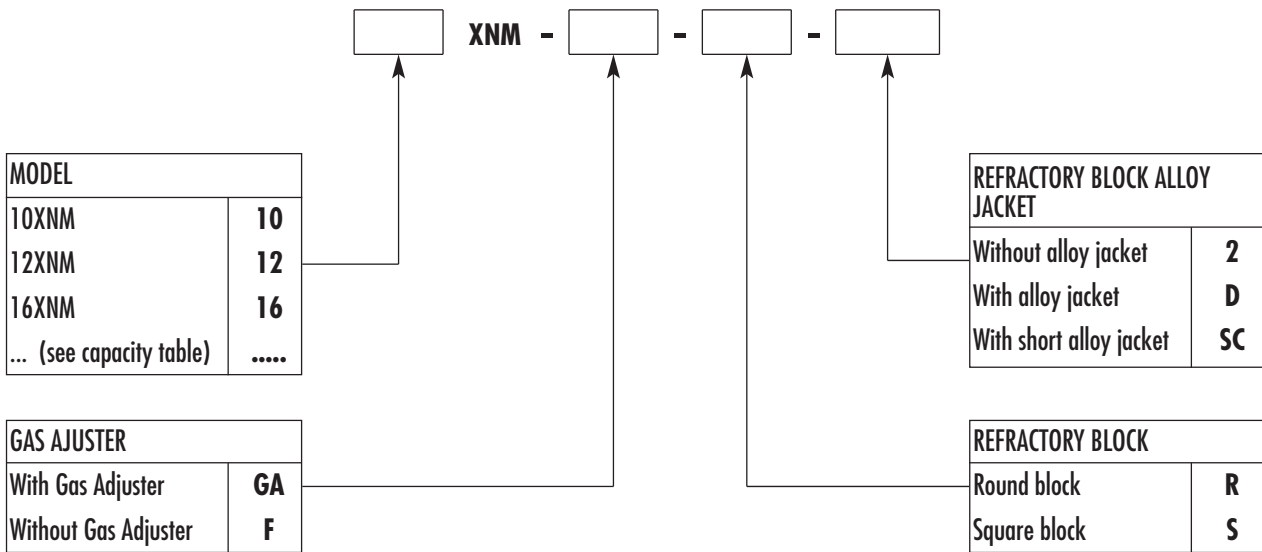

## ORDERING CODES - REFRACTORY BLOCK ONLY

