

# HIGH VELOCITY BURNERS

## EMB-SIK-NxT SERIES

### FEATURES

- Mixer body (\*): Cast iron G25
- Gas inlet body: Cast iron G25
- Flame tubes: Silicon Carbide
- Combustion head: AISI310S
- Fixing flange: Fe
- Pre-heated air: from 200 to 500°C
- Capacity range: from 100 to 700kW
- Air and gas pressure at burner: 50 mbar
- Adequate to different types of gas: CH<sub>4</sub>/L.P./propane/etc.
- NxT Technology
- Turndown range. 1 : 5
- Easily replaced electrodes.
- Light-weighted, small-sized compact burners supplied with micrometric throttle valve, spark electrode and flame rod, peepsight, calibrated orifice plate flow meters to measure air and gas flows.

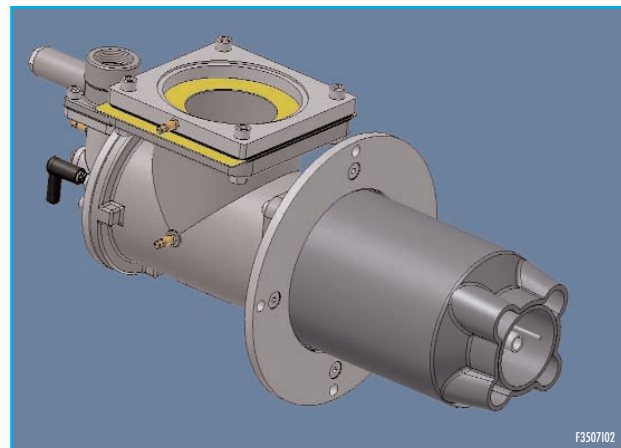
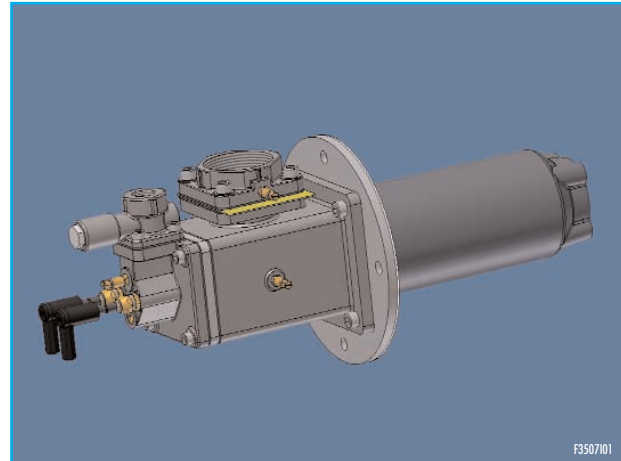

### APPLICATIONS

- Fibre insulated furnaces.
- Ceramic furnaces.
- Heat treat furnaces.
- Tunnel type furnaces.
- Truck-hearth furnaces.

### DESCRIPTION

EMB-SIK-NxT series are nozzle mix burners. Gas and air are mixed only on the combustion head, thus flashback is prevented. This allows adjustments on stoichiometric ratio and excess air. The air stream as well as the particular shape of the silicon carbide flame tube create a stiff flame allowing high heat penetration in the combustion chamber.

Maximum capacities are obtained with 50 mbar of air pressure. Two stages combustion and the specific design of flame tubes exit reach low value of emissions both for the NO<sub>x</sub> than the CO. EMB-SIK-NxT series burners are recommended in furnaces with fiber insulation. Calibration is simplified by pressure plugs which allow to know the right gas and air flow (see charts below).



**Headquarters**  
Esa S.r.l.  
Via E. Fermi 40 I-24035 Curno (BG) - Italy  
Tel. +39.035.6227411 - Fax +39.035.6227499  
esa@esacombustion.it - www.esapyronics.com

**International Sales**  
Pyronics International S.A./N.V.  
Zoning Ind., 4ème rue B-6040 Jumet - Belgium  
Tel +32.71.256970 - Fax +32.71.256979  
marketing@pyronics.be

## INSTALLATION

EMB-SIK-NxT burners are supplied with carbon steel flanges. Assembly with vertical flame may cause condensation on the electrodes and ignition problems. The furnace refractory must be built leaving free space all around the SiC flame tube (\*). This space should be filled up by insulating material to allow wall expansion (for example with ceramic fiber).

(\*) see the dimensional chart

Flexible joints are recommended for air and gas connections to the burner to allow slight movement or piping misalignment and are absolutely required in this application where pre-heated air is involved. Air and gas connections are Pyronics' standard, welding or threaded flanged type. They can be rotated by 90°.

## IGNITION AND FLAME DETECTION

Burner ignition is achieved by direct spark ignition electrode (model EN or WAND). Flame detection is archived through EN or WAND electrodes or, on request, UV-2 ultra-violet scanner.

Flame detection systems are required on all burners with furnace temperatures below 750°C.

Model	Electrode ignition	
	Ignition	Detection (*)
EMB-3-SIK-NxT	Wand	Wand
EMB-4-SIK-NxT	3EN / IS-4	3EN / IS-4
EMB-5-SIK-NxT	3EN / IS-4	3EN / IS-4
EMB-6-SIK-NxT	3EN / IS-4	3EN / IS-4
EMB-7-SIK-NxT	3EN / IS-4	3EN / IS-4

(\*) UV-2 on request

## CAPACITY TABLE

Model	Air/Gas pressure mbar	Capacity kW @ 500 °C on ratio firing
EMB-3-SIK-NxT	50	100
EMB-4-SIK-NxT	50	180
EMB-5-SIK-NxT	50	250
EMB-6-SIK-NxT	50	450
EMB-7-SIK-NxT	50	700

### AIR CAPACITY TABLE

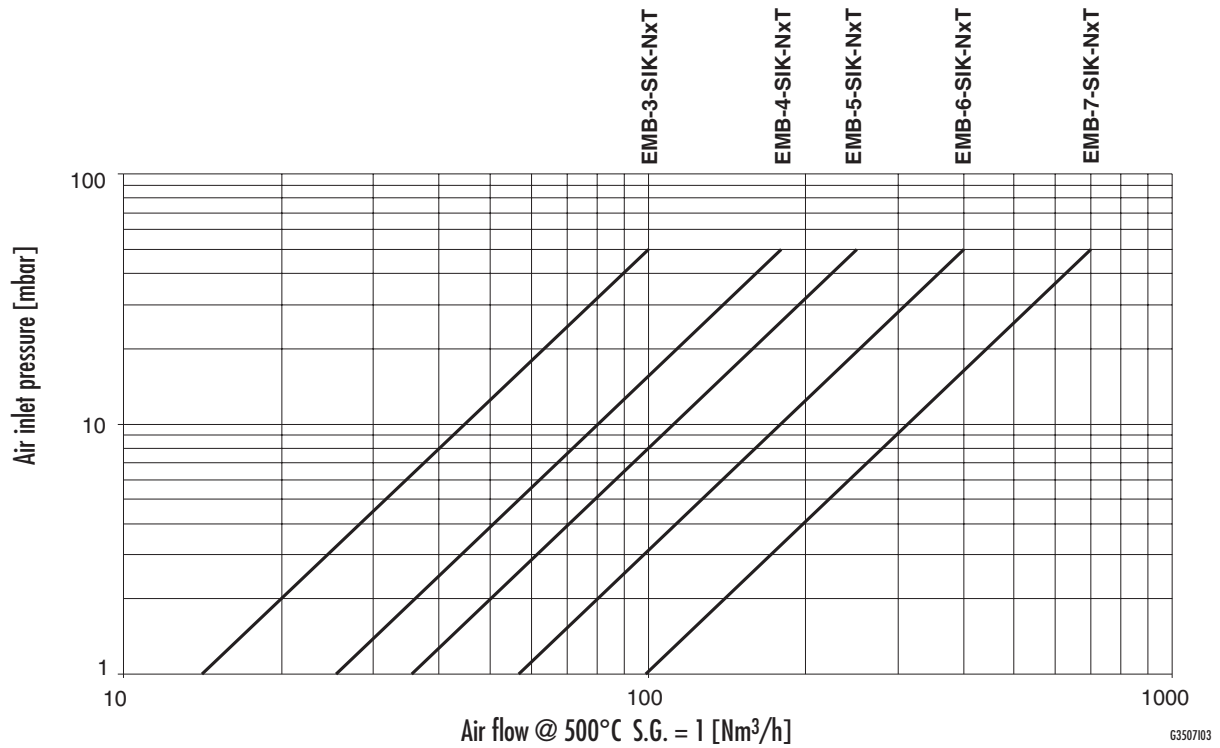

### NATURAL GAS CAPACITY TABLE

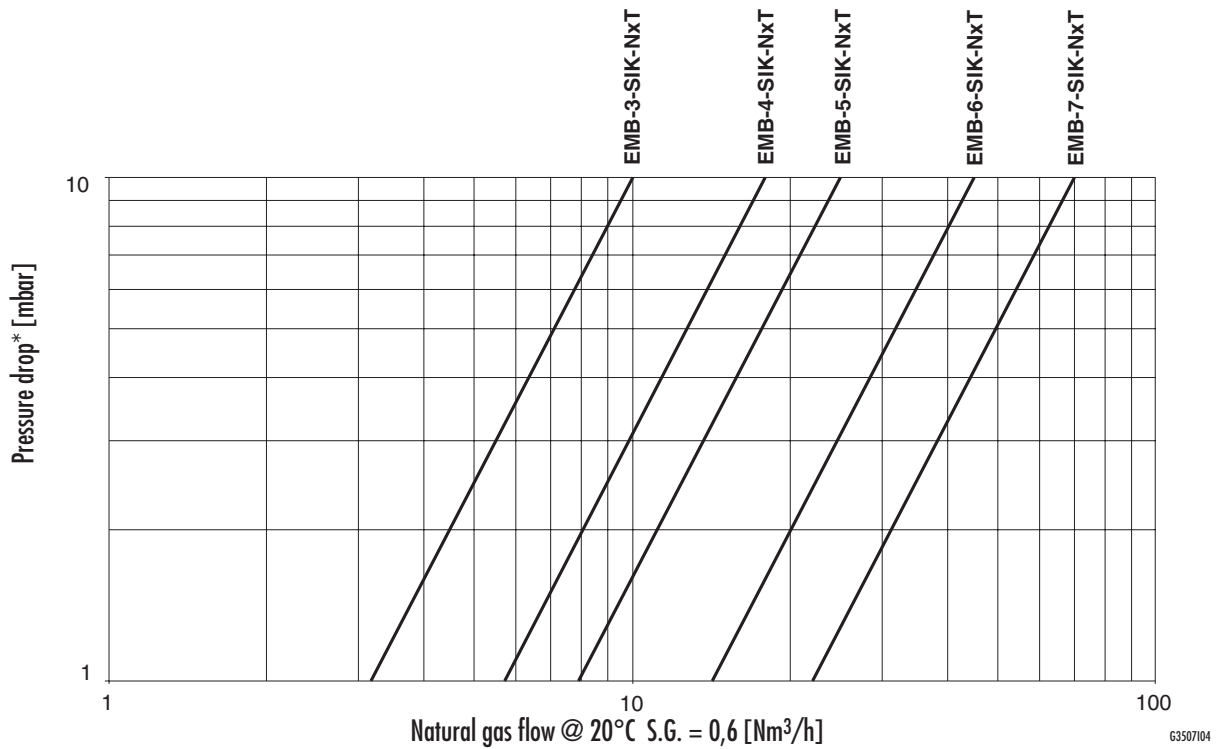

\*Pressure drop at the plugs on the burner

## EMISSIONS

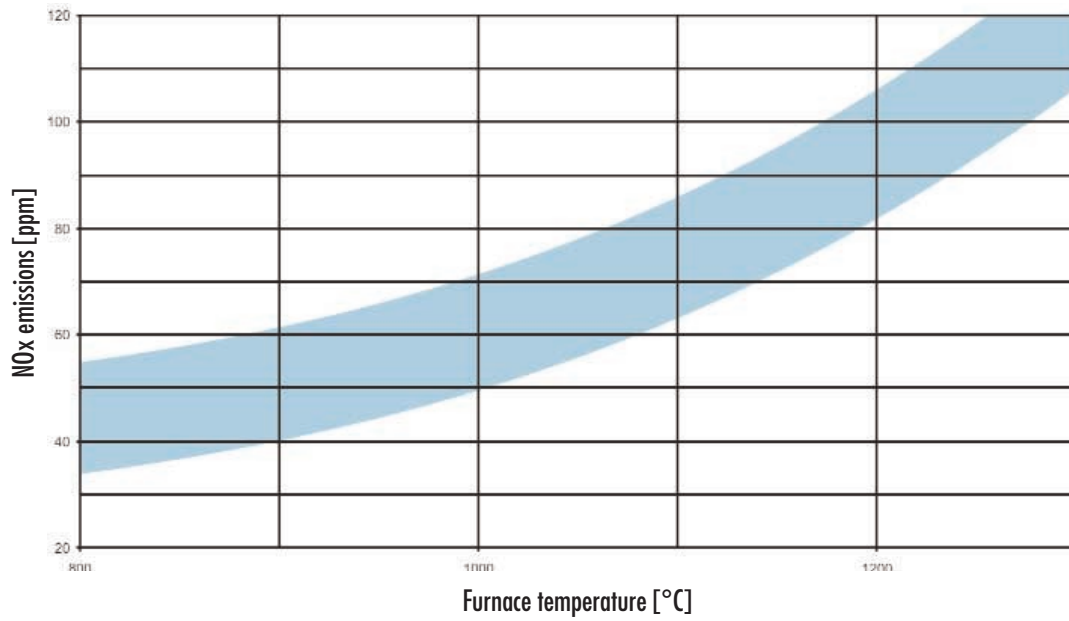

6350701

Preheated air 500 °C  
 O<sub>2</sub> = 3% 100% Maximum capacity

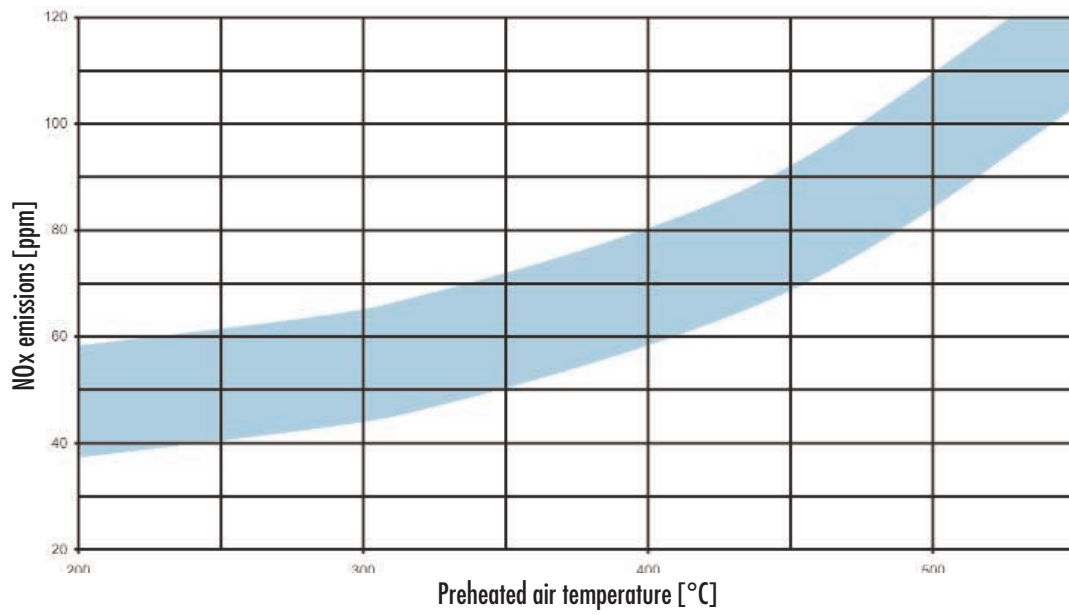

6350702

T furnace: 1200 °C  
 O<sub>2</sub> = 3% 100% Maximum capacity

## BURNER CAPACITY VS PREHEATED AIR TEMPERATURE

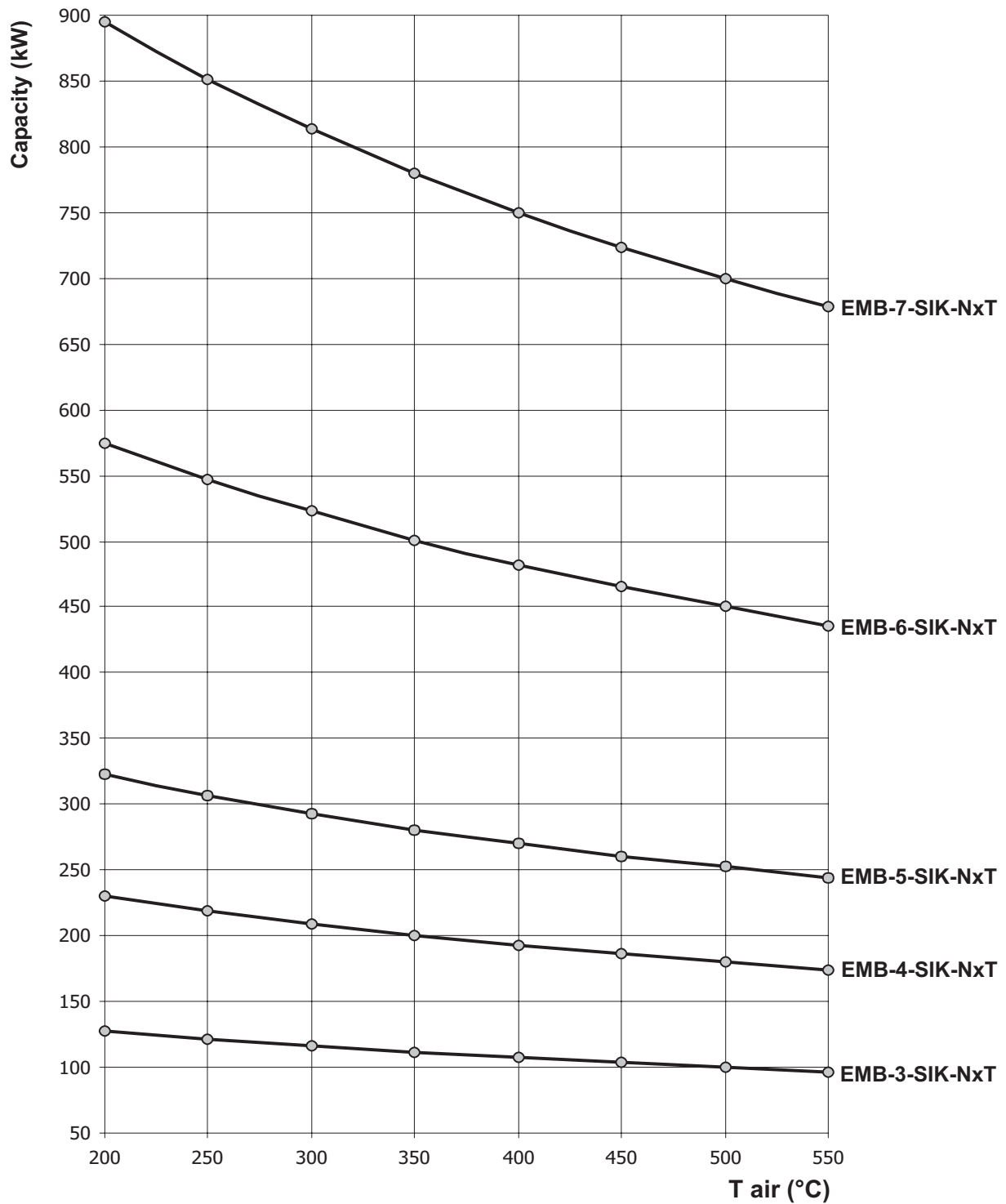

G3507105

## COMBUSTION SCHEME

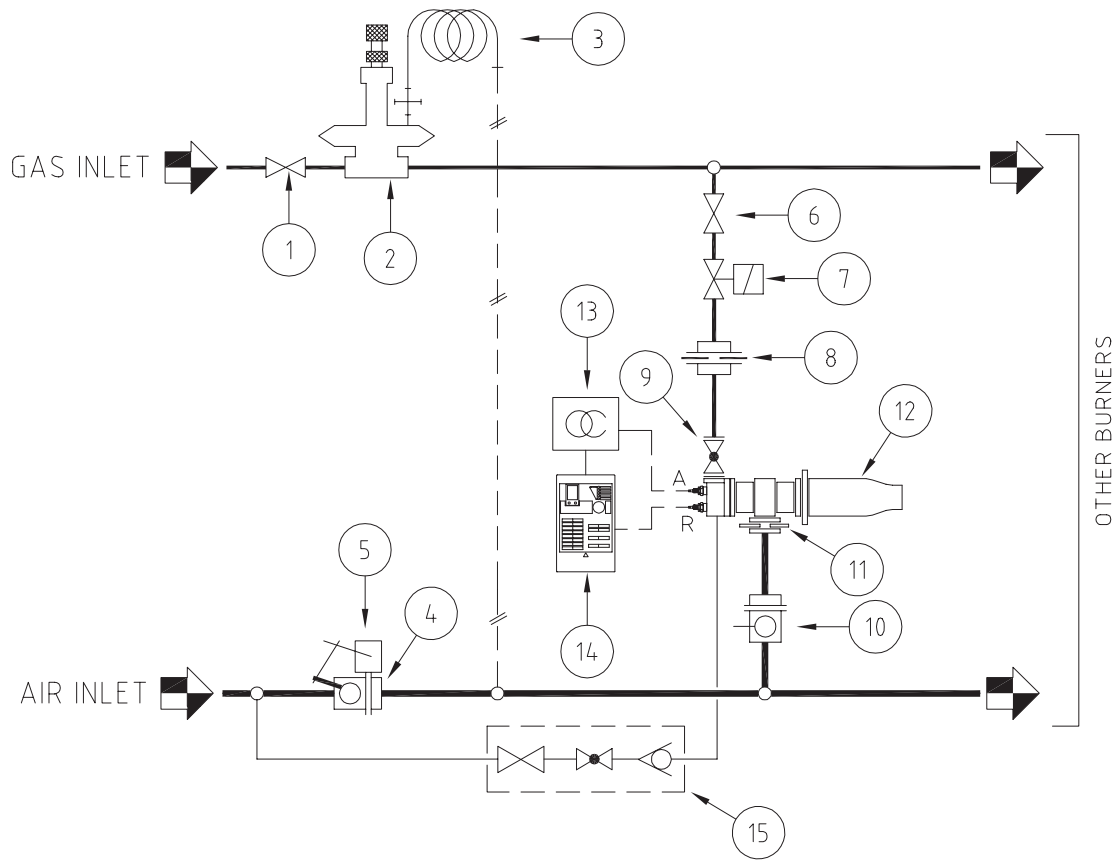

Pos.	Model Identification
1	Main gas ball valve
2	Zero governor
3	Impulse line
4	Motorized air valve
5	Electric control
6	Gas butterfly valve
7	Burner safety solenoid gas valve
8	Gas orifice flowmeter
9	Gas adjuster
10	Manual air butterfly valve
11	Air orifice flowmeter
12	Burner
13	Ignition transformer
14	Flame control
15	Premixing air feeding line (for LPG model)

D350701

## DIMENSIONS

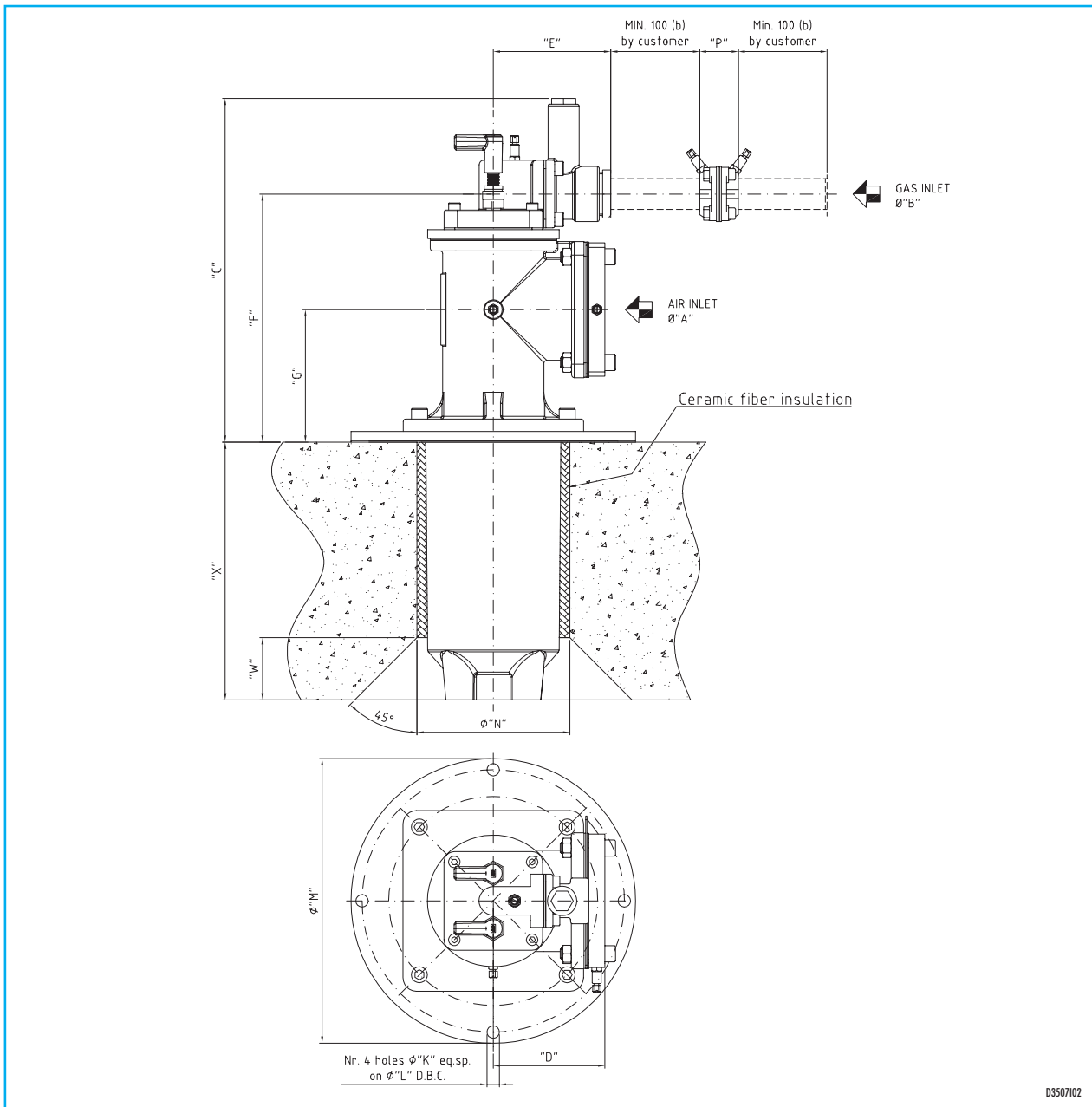

D3507102

Model	ø A	ø B	C mm	D mm	E mm	F mm	G mm	K mm	L mm	M mm	N mm	X mm	P mm	W mm
EMB-3-SIK-NxT	Rp 2.1/2"	Rp 3/4"	343	118	107	222	110	ø 14	ø 200	ø 240	ø 138	290	46	60
EMB-4-SIK-NxT	DN80	Rp 1"	356	126	107	273	149	ø 14	ø 250	ø 280	ø 172	290	46	75
EMB-5-SIK-NxT	DN100	Rp 1"	387	126	132	279	149	ø 14	ø 295	ø 320	ø 172	290	46	75
EMB-6-SIK-NxT	DN150	Rp 1.1/2"	468	156	137	355	183	ø 14	ø 295	ø 320	ø 208	290	67	75
EMB-7-SIK-NxT	DN200	Rp 2"	562	221	185	443	218	ø 15	ø 360	ø 400	ø 250	290	67	80

## FURNACE WALL FIXING SCHEME

WALL THICKNESS  
 $X > 290\text{mm}$

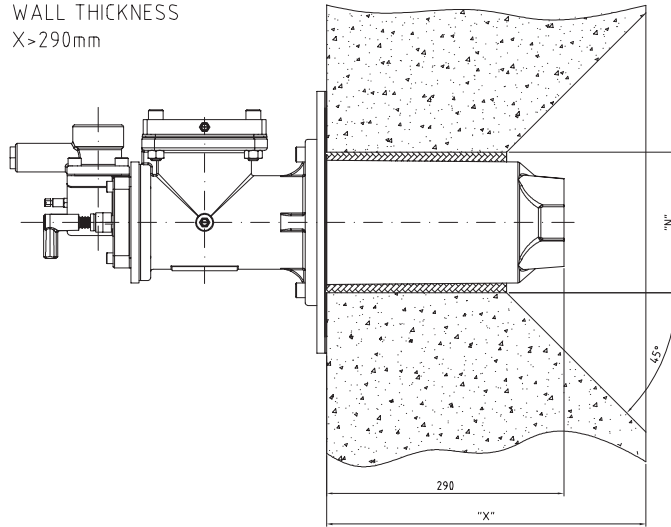

WALL THICKNESS  
 $X = 290\text{mm}$

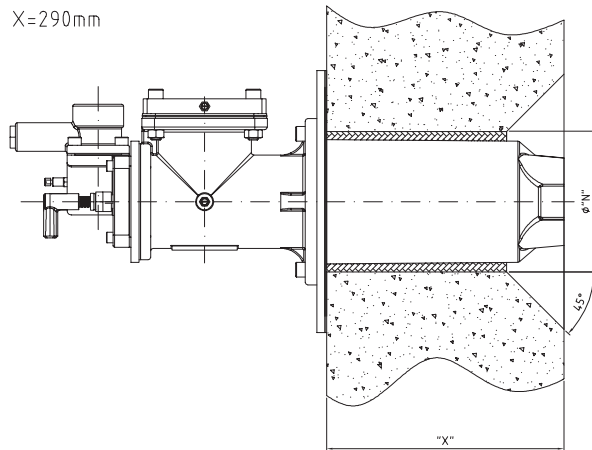

WALL THICKNESS  
 $X < 290\text{mm}$

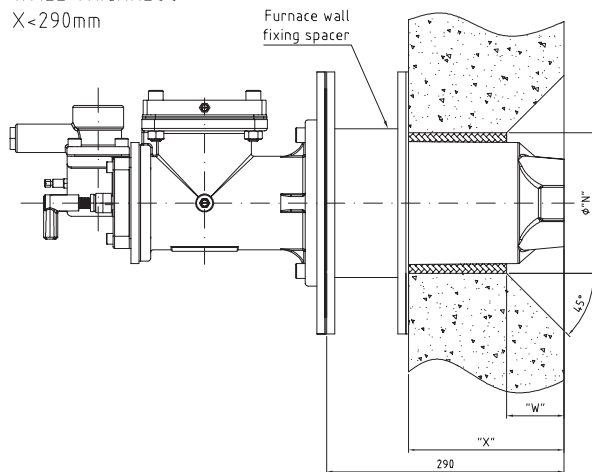

D3507/03



ORDERING CODE - BURNER

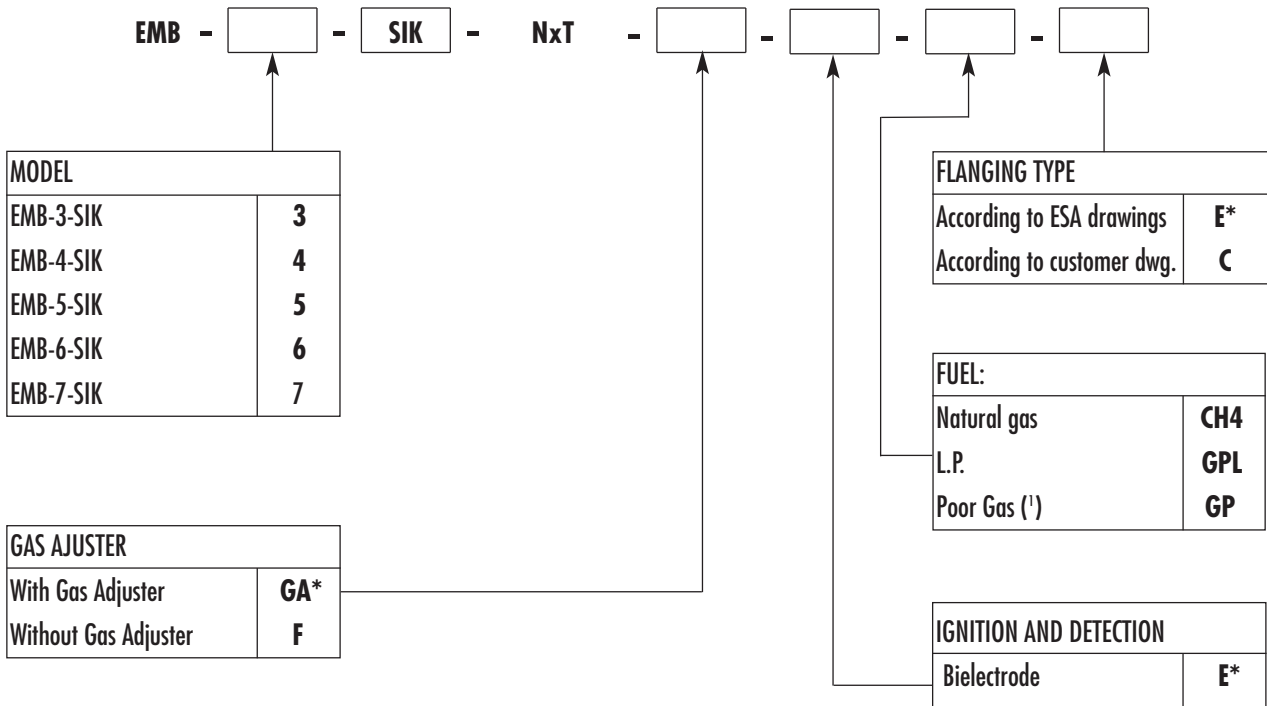

\* Standard configuration.

Note:

¹ Special manufacture made according to gas features