

# FLOW CONTROL REGULATORS - RATIO 1:1

## FCR-REG SERIES

### FEATURES

• Body and valve seat:	cast iron G20
• Valve seat:	AISI 303
• Valve stem:	AISI 303
• Diaphragms:	nitrile rubber/nylon
• Max. operating pressure:	140 mbar
• Max. differential pressure:	36 mbar
• Max. operating temperature:	65°C
• Turndown range:	10:1
• Max. air signal:	36 mbar
• Nominal air signal:	25 mbar
• Min. air signal:	0.25 mbar
• Accuracy:	low flow: +0.0/-0.1 mbar full flow: + 0.0/-1.0 mbar

### APPLICATIONS

- Air and gas flow control in pre-heated air systems (FCR).
- Piloting of zero regulators in pre-heated air systems (FCR-PC).
- Systems with varying pressure combustion chambers.



F5105101

### DESCRIPTION

FCR - flow control regulators are double diaphragm spring balanced flow ratio control regulators that offer maximum control and fuel efficiency on gas-fired applications involving pre-heated air to the burners, or where burners fire against a varying back pressure. The FCR monitors air mass flow by means of a pressure differential across a POP orifice flow meter. The signal from the POP is applied across the regulator large top diaphragm; pressure differential automatically compensates for back pressure. Lower matching "gas"

diaphragm is connected to suit the application. Three smaller diaphragms are used within regulator to balance out dynamic and static forces in control system.

The FCR holds a constant air/fuel ratio from cold start-up through hot air application. All control components are on the cold side of the system and are unaffected by high combustion air temperatures, minimizing cost and maintenance.



**Headquarters**  
Esa S.r.l.  
Via E. Fermi 40 I-24035 Curno (BG) - Italy  
Tel. +39.035.6227411 - Fax +39.035.6227499  
esa@esacombustion.it - www.esapyronics.com

**International Sales**  
Pyronics International S.A./N.V.  
Zoning Ind., 4ème rue B-6040 Jumet - Belgium  
Tel +32.71.256970 - Fax +32.71.256979  
marketing@pyronics.be

## INSTALLATION

All FCR regulators are tested, set and sealed when shipped. If adjustment or repair is necessary, the regulator should be returned to the factory.

Regulators must always be mounted in a stem-up position, in a horizontal line. Any other mounting position will cause a

malfunction. The arrow cast on the side of the valve body indicates direction flow.

Regulators should not be installed in areas where operating temperatures will exceed the maximum operating value.

## CAPACITY TABLE

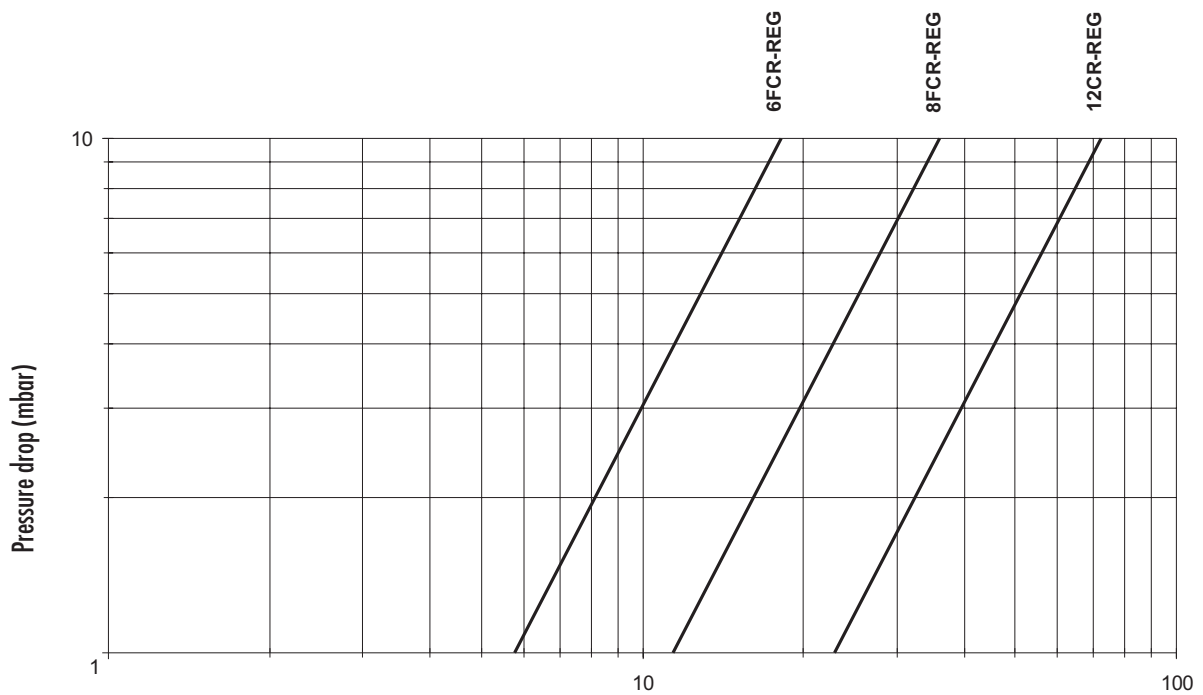

Natural gas flow @ 20°C S.G. = 0.6 (Nm³/h)

65105101

EXAMPLES OF APPLICATIONS

**PICTURE NO. 1**

The adjusted gas pressure is the same as the differential pressure measured at the calibrated air orifice flow meter.

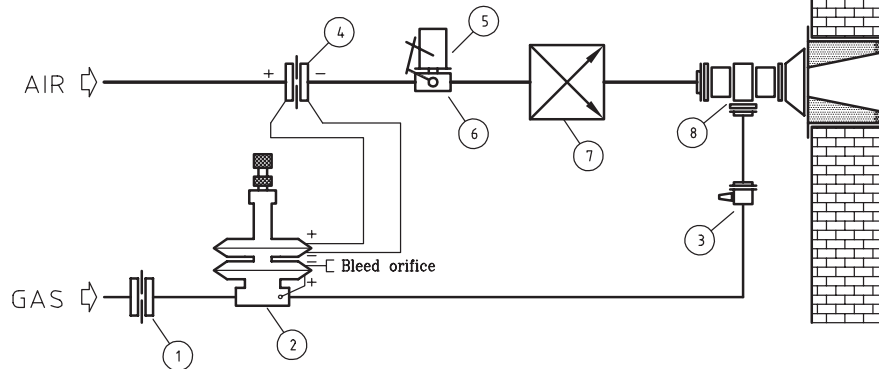

D5105E01

**PICTURE NO. 2**

The FCR-PC model is used to pilot a BZR when the gas flow required at the burner is higher than the one FCR can supply. All solutions can be applied (see Picture no. 3 ÷ Picture no. 5) just like for the simple FCR.

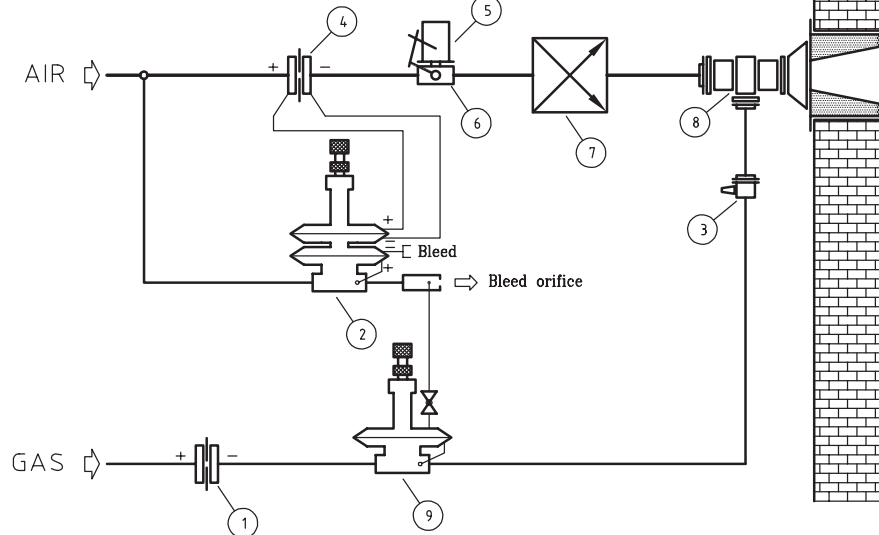

D5105E02

Pos	Model identification
1	Orifice flow meter for $\Delta P$ gas
2	Flow regulator
3	Gas adjuster
4	Orifice flow meter for $\Delta P$ air
5	Electric control
6	Motorized air valve
7	Heat exchanger
8	Burner
9	Balanced zero regulator

**NOTE:**

The above table refers to the pictures of "Examples of applications".

EXAMPLES OF APPLICATIONS

**PICTURE NO. 3**

When the adjusted gas pressure is not sufficient to supply the burner at its maximum capacity, it is possible to load the lower chamber of the regulator only with the differential pressure taken between the gas adjuster.

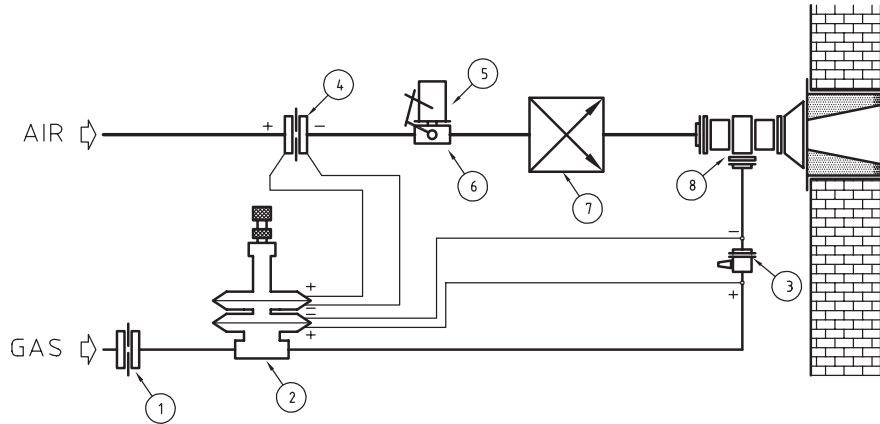

D5105I03

**PICTURE NO. 4**

This application is necessary when the pressure in the combustion chamber is variable (positive or negative). In this case the lower chamber of the regulator is piloted with the pressure of the combustion chamber, as shown in the picture.

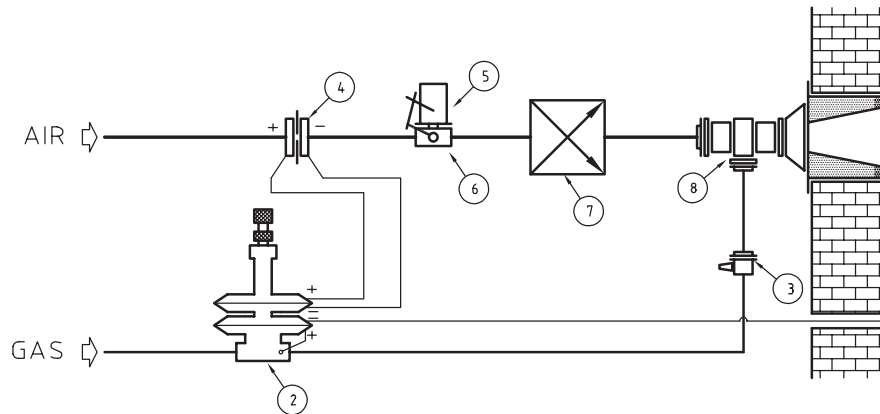

D5105I04

**PICTURE NO. 5**

The FCR regulator is balanced when the pressure drops on the POP air and gas orifice flow meters are the same. POP orifice flow meters are sized according to the desirable air/gas ratio.

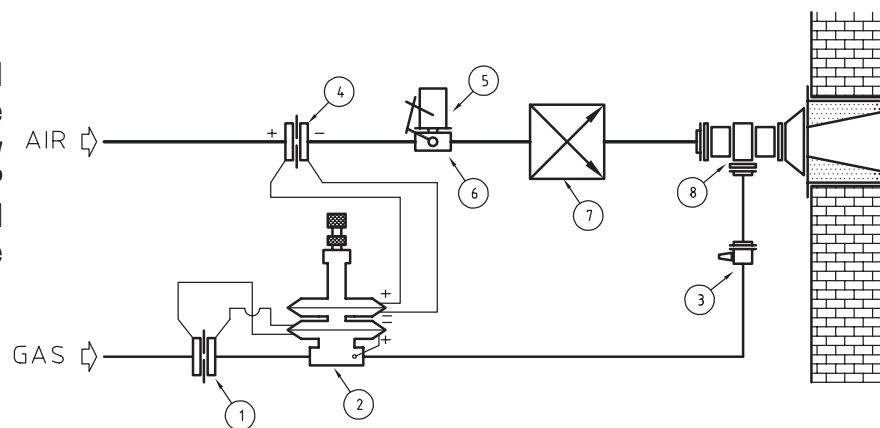

D5105I05

## DIMENSIONS

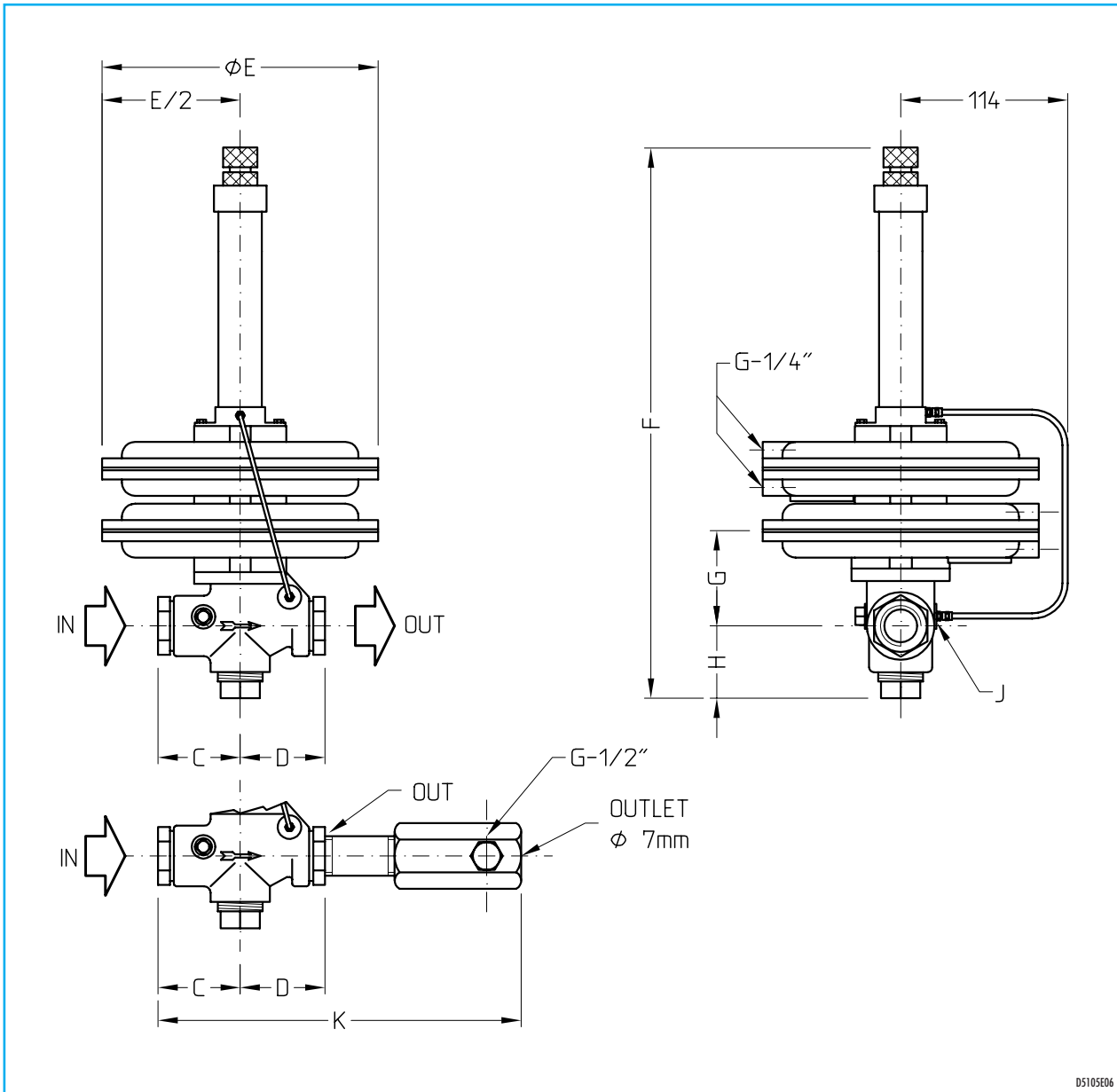

DS105E06

Model	In	Out	C mm	D mm	E ø mm	F mm	G mm	H mm	J bsp	K mm	Weight kg
6 FCR	G - 3/4"	G - 3/4"	64	64	210	432	73	48	1/8"	—	4.65
6 FCR - PC	G - 3/4"	G - 3/4"	64	64	210	432	73	48	1/8"	213	5.80
8 FCR	G - 1"	G - 1"	60	60	248	457	70	51	1/4"	—	6.55
12FCR	G-1.1/2"	G-1.1/2"	76.2	88.9	210	609	118	86.5	1/4"	—	8.60



NOTE: Based on the company's policy aimed at a continuous improvement on product quality, ESA-PYRONICS reserves the right to bring changes to the technical characteristics of this device without previous notice. Our catalog updated to the latest version is available on our web site [www.esapyronics.com](http://www.esapyronics.com) and it is possible to download modified documents

WARNING: When operating, this combustion system can be dangerous and cause harm to persons or damage to equipment. Every burner must be provided with a protection device that monitors the combustion. The installation, adjustment and maintenance operations should only be performed by trained and qualified personnel.