

# OIL REGULATORS

## RFG SERIES

### FEATURES

- |                              |                                   |
|------------------------------|-----------------------------------|
| • Body and valve seat:       | AVP                               |
| • Shutter seat:              | C40                               |
| • Valve stem:                | AISI303                           |
| • Diaphragm:                 | anti-petrol rubbered fabrics      |
| • Max viscosity:             | 4°E                               |
| • Max operating pressure:    | 7 bar                             |
| • Max differential pressure: | 0.7 bar                           |
| • Max operating temperature: | 80 °C                             |
| • Max oil/air flow ratio:    | 30:1                              |
| • Operation position:        | see arrows cast on the valve body |

### APPLICATIONS

- Oil/air regulator in adjusting systems



E5301/01

### DESCRIPTION

Oil Regulators RFG series are used to proportion fuel flows to modulating oil burners. Combustion air flows produce a proportional pressure signal that is applied to the regulator to set the outlet oil pressure. On initial adjustment the desired oil flow rate is set to match the burner air capacities. The regulator holds this oil to air ratio at all firing rates. Head input turndown over a 10 to 1 range is achieved by varying the position of the combustion air control valve. This simple single valve control is readily interlocked with control motors to process temperature, pressure or other functions to provide precisely the heat required at any time. A constant oil pressure is required at the RFG inlet. A variation of 0.35 bar at the inlet can cause a 2% error in flow control. Air pressure from the load line forces the main diaphragm upwards opening in the outlet chamber applies pressure on the oil piston which opposes movement of the main diaphragm and tends to close the oil outlet valve. Since the main diaphragm has an area 30 times larger than the piston area, oil flows from the regulator at a rate that produces an outlet oil pressure 30 times the inlet air pressure.

### INSTALLATION

- The regulator should be installed in a horizontal line with the adjustment stem down. The arrow cast on the valve body indicates direction of flow.
- Inlet oil pressure to the regulator should be 0.7 bar higher than the maximum outlet pressure.
- A filter must be installed upstream of the regulator to prevent clogging of the valves.
- For optimum performance accuracy the regulator should be on the same level as the burners. Where burners are on different levels, separate regulators should serve each level.
- Avoid long oil lines between the regulator and burners.



**Headquarters**  
Esa S.r.l.  
Via E. Fermi 40 I-24035 Curno (BG) - Italy  
Tel. +39.035.6227411 - Fax +39.035.6227499  
esa@esacombustion.it - www.esapyronics.com

**International Sales**  
Pyronics International S.A./N.V.  
Zoning Ind., 4ème rue B-6040 Jumet - Belgium  
Tel +32.71.256970 - Fax +32.71.256979  
marketing@pyronics.be

## CAPACITY TABLE

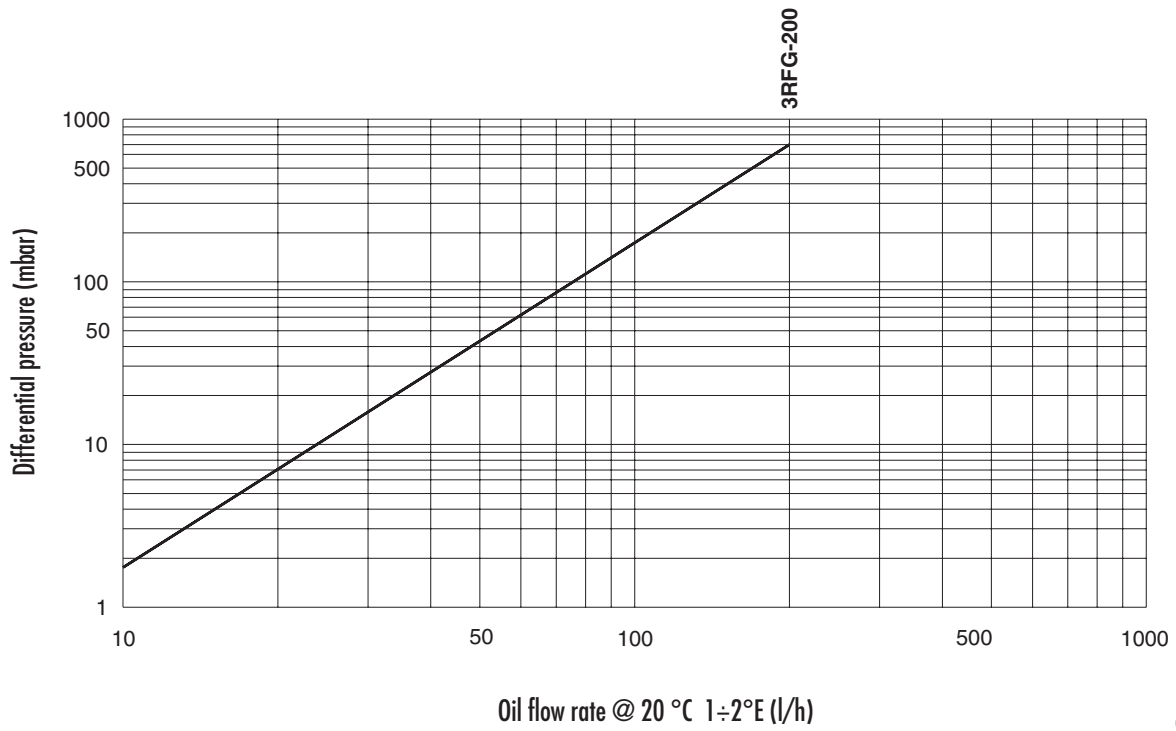

**NOTE:**

Inlet oil pressure to the regulator should be 70 mbar higher than the maximum outlet pressure.  
 (Example: 70 mbar combustion air pressure produces 2.2 bar outlet oil pressure; inlet oil pressure should be 3.2 bar)

FLOW CHART (FOR ADJUSTING)

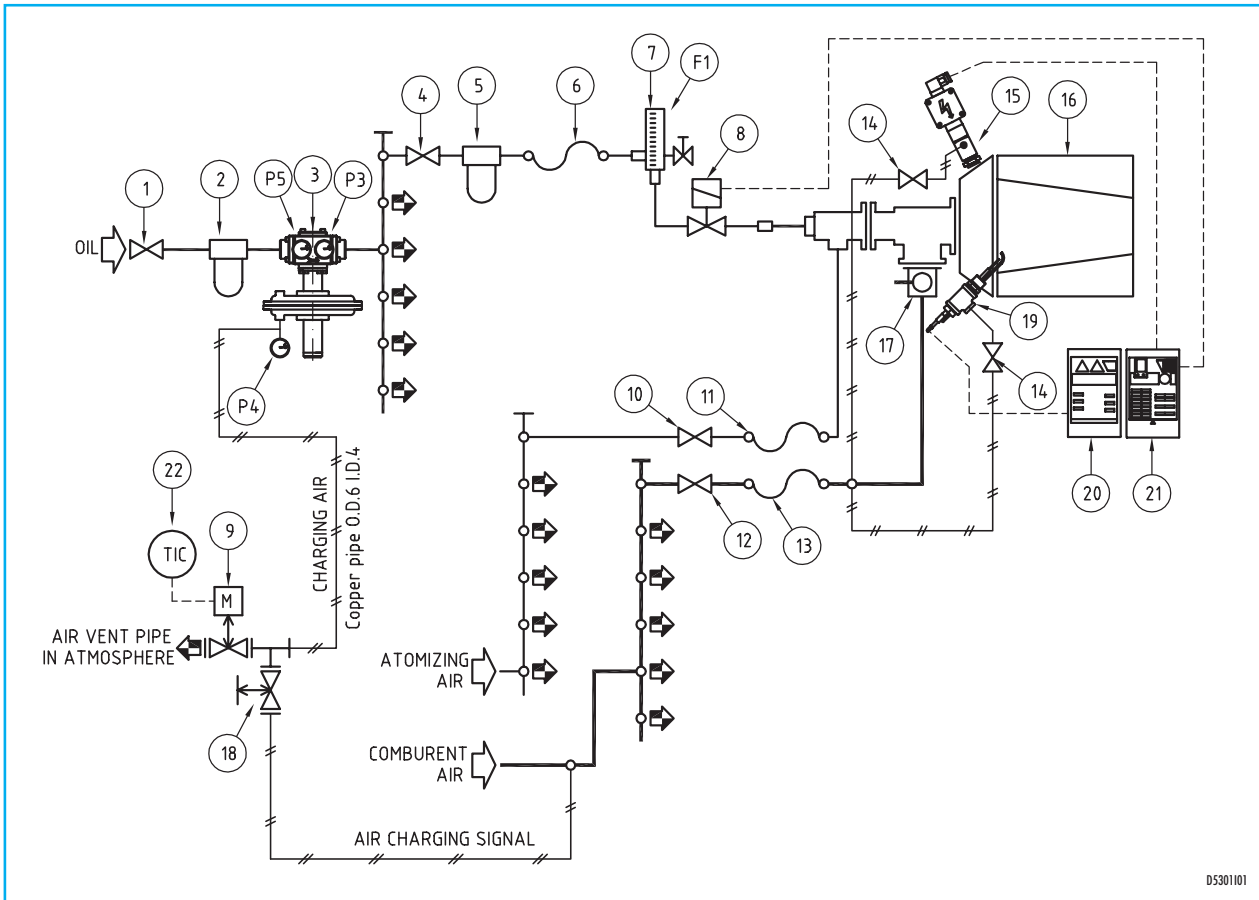

D5301101

Pos.	Description	Pos.	Description
1	Ball valve	12	Air valve
2	Oil filter	13	Flexible pipe
3	Regulator oil-air ratio	14	Ball valve
4	Ball valve	15	Photocell with bracket
5	Oil filter	16	Burner
6	Flexible pipe	17	Manual butterfly valve
7	Flow meter	18	Throttle orifice
8	Oil solenoid valve	19	Ignition electrode
9	Motorized valve	20	Ignition transformer
10	Atomization air valve	21	Flame control device
11	Flexible pipe	22	Zone thermoregulator

## FLOW CHART (THREE STEPS)

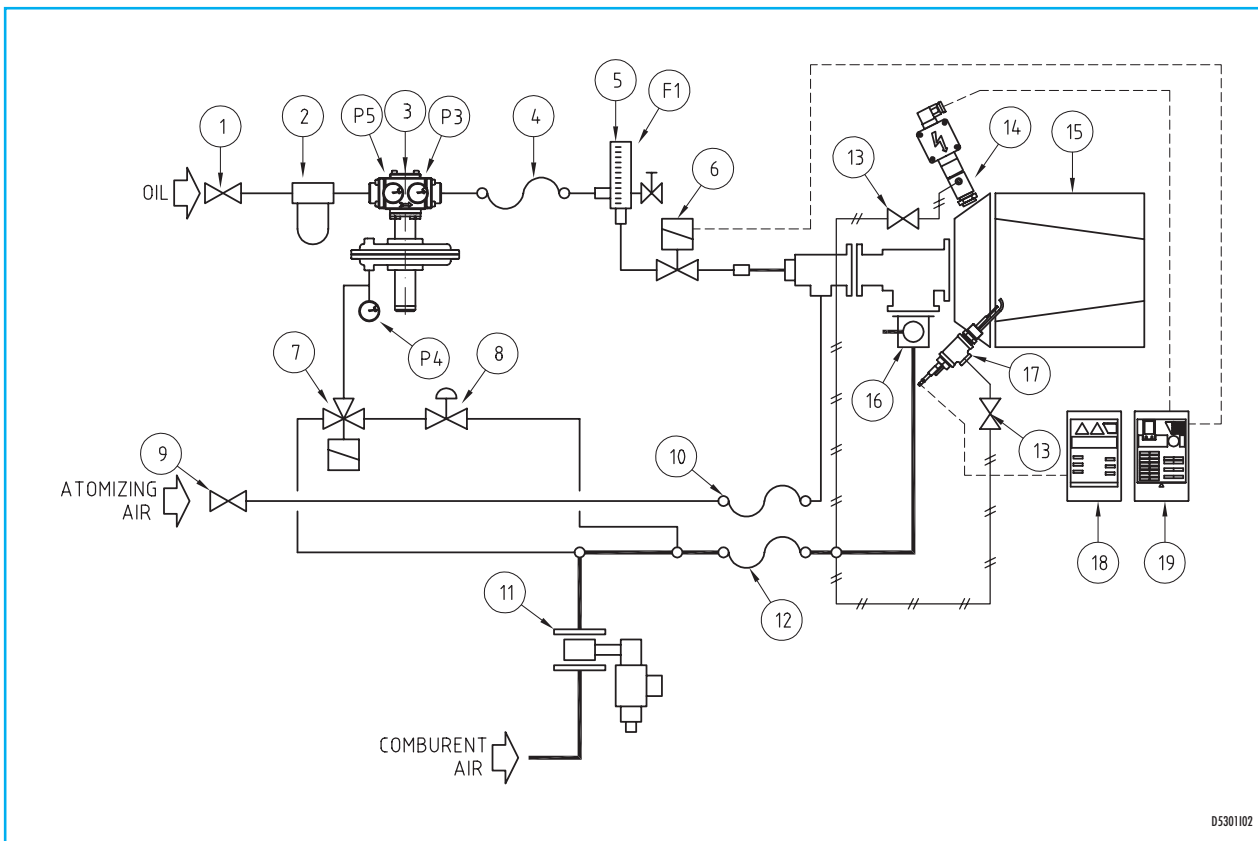

Pos.	Description	Pos.	Description
1	Ball valve	11	Air valve
2	Oil filter	12	Flexible pipe
3	Regulator oil-air ratio	13	Ball valve
4	Flexible pipe	14	Photocell with bracket
5	Flow meter	15	Burner
6	Oil solenoid valve	16	Manual butterfly valve
7	3 way solenoid valve	17	Ignition electrode
8	Reducing regulator	18	Ignition transformer
9	Atomization air valve	19	Flame control device
10	Flexible pipe		

## DIMENSIONS

