

ORIFICE FLOW METERS WITH CHAMBERS MEASURING RINGS POP-U-S SERIES

FEATURES

- | | |
|-----------------------------------|---------------|
| • UNI PN6 flanges: | iron |
| • Chamber measuring rings: | iron |
| • Disc: | AISI304 |
| • Max. operating temperature: | 400 °C |
| • Max. operating pressure: | 6 bar |
| • Gasket | AFM 20 |
| • According to European standard: | EN ISO 5167-1 |

APPLICATIONS

- Orifice flow meters.
- Connected to ESA PT-1 transmitter for measuring air and gas flow.



F5719/01

DESCRIPTION

The POP-U-S flanges are direct reading precision flow meters characterized by a primary element, a diaphragm, and by a secondary element, usually an MAG manometer differential, (Bulletin E5275) or by an ESA PT-1 transmitter (Bulletin E7010). The POP-U-S calibrated flanges have welding connections (from DN20 to DN 450) directly in pipes and the pressure taps are located in the flanges with "O" ring chamber. Installation is easy. Orifice flow meters are accurate and may be constructed with various types of material depending on the application.

Orifice flow meters are ideal for measuring air and gas flows in combustion systems. As a matter of fact air-fuel ratio adjustment of burners is simplified when true air and gas rates are known. Available accessories to be used with the orifice flow meters are MAG differential manometers with mounting flanges. ESA PT-1 pressure transmitters are also available for electronic ratio adjustment which allow for the transmission (through 0÷20 mA or 4÷20 mA signal) of the data about the capacity to remote equipments: thermoregulators, totalizers, etc.



F5719/02



Headquarters
Esa S.r.l.
Via E. Fermi 40 I-24035 Curno (BG) - Italy
Tel. +39.035.6227411 - Fax +39.035.6227499
esa@esacombustion.it - www.esapyronics.com

International Sales
Pyronics International S.A./N.V.
Zoning Ind., 4ème rue B-6040 Jumet - Belgium
Tel +32.71.256970 - Fax +32.71.256979
marketing@pyronics.be

INSTALLATION

Calibrated orifice flow meters should have at least 10 pipe diameters upstream and 5 pipe diameters downstream of smooth, clean, straight pipe for accurate readings.

The UNI table listed below states the minimum distances according to the diameters “ β ” ratio and to the type of connections located on the pipes on which flanges will be mounted. The figures without brackets

stand for “probable supplementary null error”, those in brackets stand for “probable supplementary $\pm 0.5\%$ error”.

Lengths listed below are minimum lengths. It is always advisable to adopt lengths longer than the listed ones, in particular for research it is advisable to double upstream lengths to obtain “probable supplementary null error”.

MINIMUM LENGTHS OF STRAIGHT PIPE UPSTREAM AND DOWNSTREAM OF PRIMARY ELEMENT:

Diameters ratio β	Minimum length upstream*							Minimum length downstream*
	90° curb or T item	No. 2 or more 90° elbow on same level	No. 2 or more 90° elbow on different levels	Enlargement from 0,5D to D on a D to 2D length	Thinning from 2D to D on a 1.5D to 3.5D length	Fully open shutter valve	Fully open gate valve	Any situation
≤ 0.20	10 (6)	14 (7)	34 (17)	16 (8)	5	18 (9)	12 (6)	4 (2)
0.25	10 (6)	14 (7)	34 (17)	16 (8)	5	18 (9)	12 (6)	4 (2)
0.30	10 (6)	16 (8)	34 (17)	16 (8)	5	18 (9)	12 (6)	5 (2.5)
0.35	12 (6)	16 (8)	36 (18)	16 (8)	5	18 (9)	12 (6)	5 (2.5)
0.40	14 (7)	18 (9)	36 (18)	16 (8)	5	20 (10)	12 (6)	6 (3)
0.45	14 (7)	18 (9)	38 (19)	17 (9)	5	20 (10)	12 (6)	6 (3)
0.50	14 (7)	20 (10)	40 (20)	18 (9)	6 (5)	22 (11)	12 (6)	6 (3)
0.55	16 (8)	22 (11)	44 (22)	20 (10)	8 (5)	24 (12)	14 (7)	6 (3)
0.60	18 (9)	26 (13)	48 (24)	22 (11)	9 (5)	26 (13)	14 (7)	7 (3.5)
0.65	22 (11)	32 (16)	54 (27)	25 (13)	11 (6)	28 (14)	16 (8)	7 (3.5)
0.70	28 (14)	36 (18)	62 (31)	30 (15)	14 (7)	32 (16)	20 (10)	7 (3.5)
0.75	36 (18)	42 (21)	70 (35)	38 (19)	22 (11)	36 (18)	24 (12)	8 (4)
0.80	46 (23)	50 (25)	80 (40)	54 (27)	30 (15)	44 (22)	30 (15)	8 (4)
All β values	Special items				Minimum length upstream*			
	Important diameter drop ($D_1/D_2 \geq 0.5$)				30 (15)			
	Thermometric position \leq diameter 0.03D $0.03D \leq$ diameter \leq 0.13D				5 (3) 20 (10)			

* The figures without brackets stand for “probable supplementary null error”, those in brackets stand for “probable supplementary $\pm 0.5\%$ error”. Lengths should be measured from the upstream face to the downstream face of the primary element and are calculated in multiples of the D diameter.

PIPING FLOW SPEED TABLE (UNI 8863)

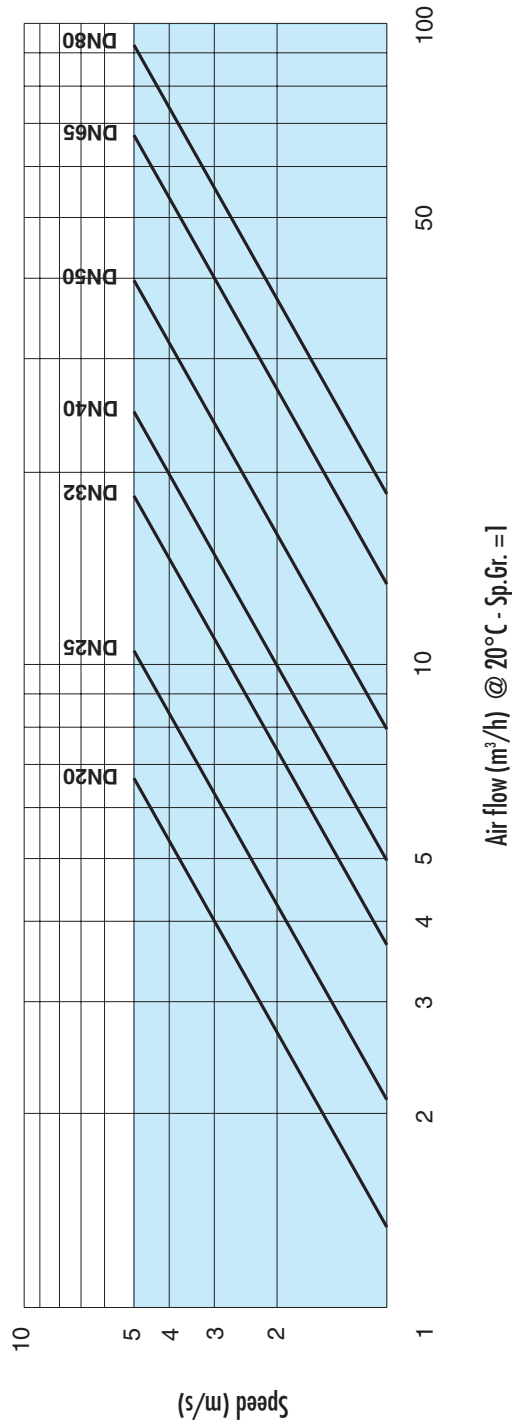

65719101

AIR ORIFICE TABLE

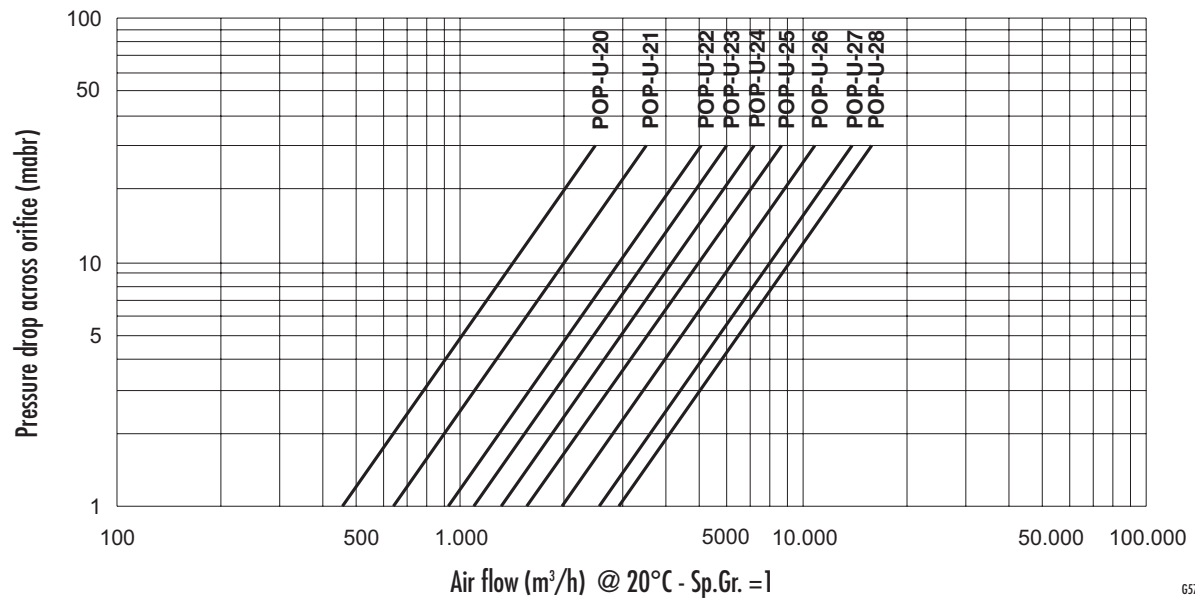
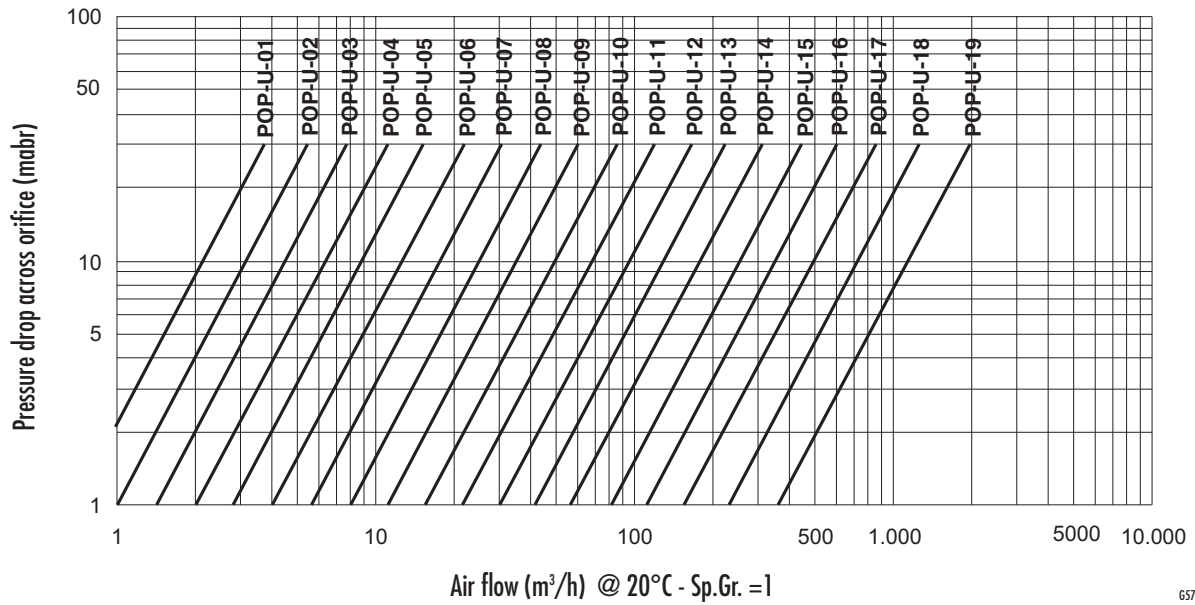

CORRECTING TABLES

SPECIFIC GRAVITY FACTORS										
Specific gravity (air=1)	0.07	0.2	0.4	0.5	0.6	0.7	0.8	1.0	1.5	2.0
Multiplying factor *	3.8	2.2	1.6	1.4	1.3	1.2	1.1	1.0	0.82	0.71

TEMPERATURE FACTORS										
Temperature (°C)	20	50	100	150	200	250	300	350	400	450
Multiplying factor *	1	0.95	0.89	0.84	0.79	0.75	0.72	0.69	0.66	0.64

RELATIVE PRESSURE FACTORS											
Pressure (mbar)	0	50	100	150	200	250	300	400	500	700	1000
Multiplying factor *	1	1.05	1.1	1.15	1.20	1.25	1.30	1.39	1.49	1.69	1.99

* Values to be multiplied to flow rate value before looking at orifice tables.

NATURAL GAS ORIFICE TABLE

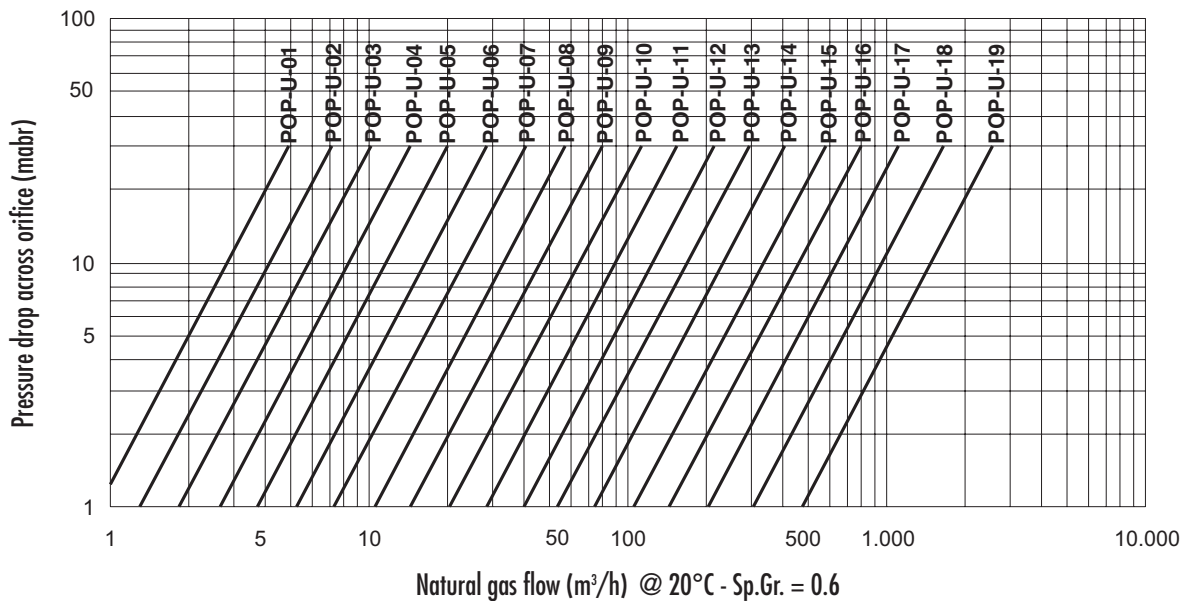

Characteristic curves on these tables show flow rate values (Nm³/h) relative to pressure loss (mbar) for standard orifices; curves are good for atmospheric pressure (1.013 bar) and flow temperature 20°C.

For flow rate values relative to different parameter, please refer to correcting tables for specific gravity, temperature and pressure. These tables show characteristics of standard orifices useful for an early choice of orifice flow meter.

STANDARD ORIFICE PLATE TABLE

Catalog no.		Orifice plates listed are the minimum and the maximum diameters recommended per indicated pipe size																														
		-01	-02	-03	-04	-05	-06	-07	-08	-09	-10	-11	-12	-13	-14	-15	-16	-17	-18	-19	-20	-21	-22	-23	-24	-25	-26	-27	-28			
6 POP-U-S	DN 20	██████████																														
8 POP-U-S	DN 25	██████████																														
10 POP-U-S	DN 32		██████████																													
12 POP-U-S	DN 40			██████████																												
16 POP-U-S	DN 50				██████████																											
20 POP-U-S	DN 65					██████████																										
24 POP-U-S	DN 80						██████████																									
32 POP-U-S	DN 100							██████████																								
40 POP-U-S	DN 125								██████████																							
48 POP-U-S	DN 150									██████████																						
64 POP-U-S	DN 200										██████████																					
80 POP-U-S	DN 250											██████████																				
96 POP-U-S	DN 300												██████████																			
112 POP-U-S	DN 350													██████████																		
128 POP-U-S	DN 400														██████████																	
144 POP-U-S	DN 450															██████████																

NOTE:

This table shows orifice flow meters suitable for orifice plate selected on previous tables. Orifice must be selected also according to flow speed in pipes, that should be lower than 20 m/s (see piping flow speed table).

After having received customer's order and all useful informations (see "Ordering information"),

ESA-PYRONICS calculates orifice dimension and verifies its applicability. With each flow meter, ESA-PYRONICS supply its orifice calculus and ΔP -capacity tables.

DIMENSIONS

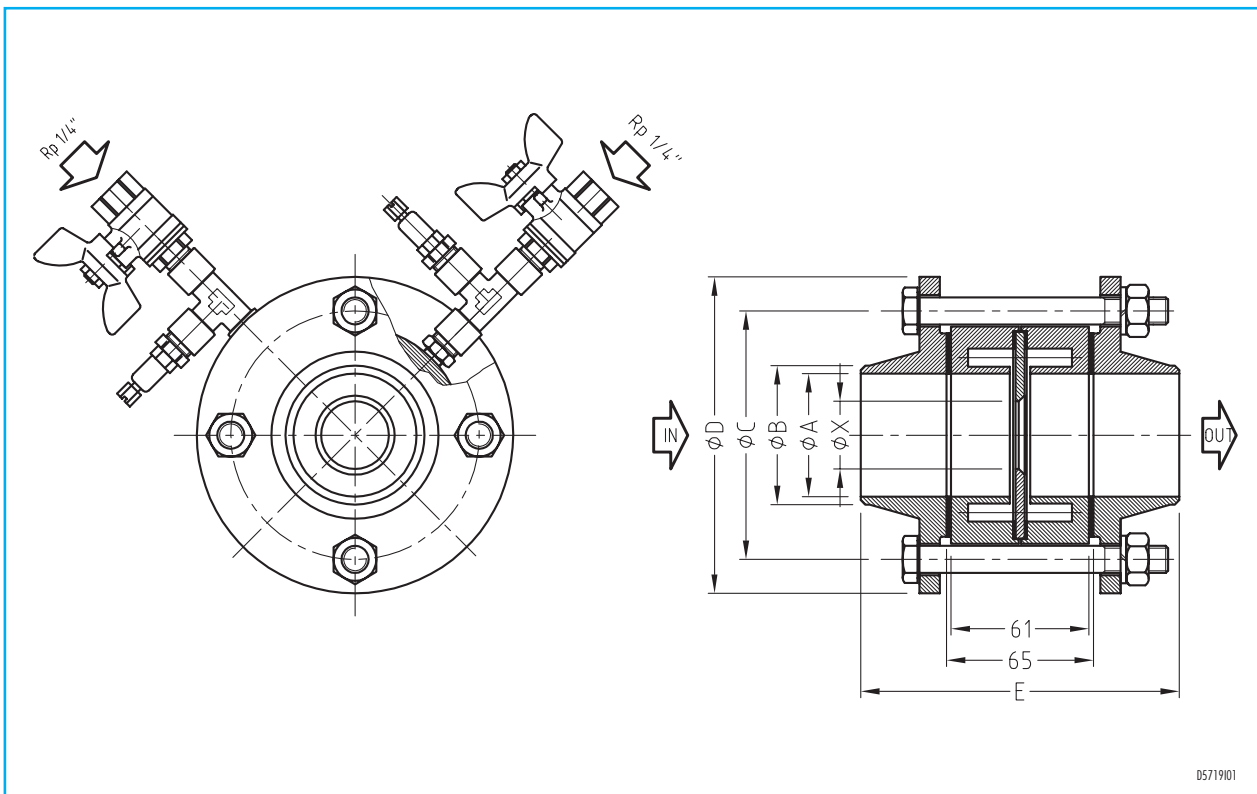

05719101

CATALOG No.	DN PN	ϕ A mm	ϕ B mm	No. holes	ϕ C mm	ϕ D mm	E mm
6 POP-U-S	DN20 PN6	23	28	4	65	90	129
8 POP-U-S	DN25 PN6	29	34.5	4	75	100	135
10 POP-U-S	DN32 PN6	37.5	43.5	4	90	120	135
12 POP-U-S	DN40 PN6	43.5	49.5	4	100	130	141
16 POP-U-S	DN50 PN6	54.5	61.5	4	110	140	141
20 POP-U-S	DN65 PN6	70	77	4	130	160	141
24 POP-U-S	DN80 PN6	82.5	90	4	150	190	149
32 POP-U-S	DN100 PN6	108	115.5	4	170	210	155
40 POP-U-S	DN125 PN6	133	141	8	200	240	161
48 POP-U-S	DN150 PN6	160.5	170.5	8	225	265	161
64 POP-U-S	DN200 PN6	211	221	8	280	320	175
80 POP-U-S	DN250 PN6	264	275	12	335	375	185
96 POP-U-S	DN300 PN6	314	326	12	395	440	189
112 POP-U-S	DN350 PN6	344.5	357.5	12	445	490	189
128 POP-U-S	DN400 PN6	394.5	408.5	16	495	540	195
144 POP-U-S	DN450 PN6	444.4	459	16	550	595	195

TYPICAL INSTALLATION

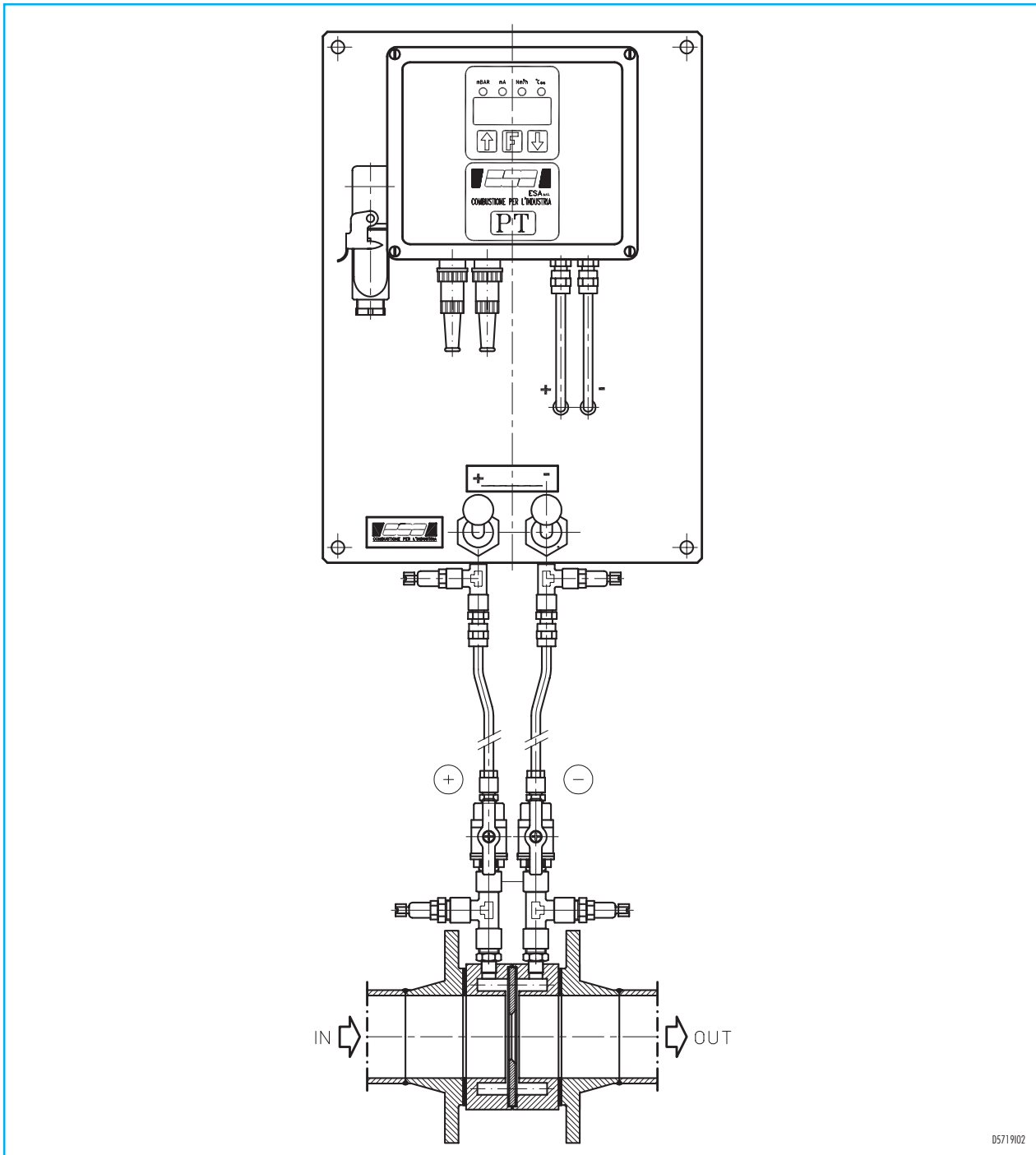

ORDERING INFORMATION

- Specify the type of fluid.
- Specify the nominal flow.
- Specify the nominal pressure differential.
- Specify operating temperature.
- Specify operating pressure.
- Specify the diameter of the pipe (DN).



NOTE: Based on the company's policy aimed at a continuous improvement on product quality, ESA-PYRONICS reserves the right to bring changes to the technical characteristics of this device without previous notice. Our catalog updated to the latest version is available on our web site www.esapyronics.com and it is possible to download modified documents

WARNING: When operating, this combustion system can be dangerous and cause harm to persons or damage to equipment. Every burner must be provided with a protection device that monitors the combustion. The installation, adjustment and maintenance operations should only be performed by trained and qualified personnel.